

Voltus-XFi Custom Power Integrity Solution User Guide

**Product Version IC23.1
November 2023**

© 2023 Cadence Design Systems, Inc. All rights reserved.
Printed in the United States of America.

Cadence Design Systems, Inc. (Cadence), 2655 Seely Ave., San Jose, CA 95134, USA.

Trademarks: Trademarks and service marks of Cadence Design Systems, Inc. (Cadence) contained in this document are attributed to Cadence with the appropriate symbol. For queries regarding Cadence's trademarks, contact the corporate legal department at the address shown above or call 1-800-862-4522.

All other trademarks are the property of their respective holders.

Restricted Print Permission: This publication is protected by copyright and any unauthorized use of this publication may violate copyright, trademark, and other laws. Except as specified in this permission statement, this publication may not be copied, reproduced, modified, published, uploaded, posted, transmitted, or distributed in any way, without prior written permission from Cadence. This statement grants you permission to print one (1) hard copy of this publication subject to the following conditions:

1. The publication may be used solely for personal, informational, and noncommercial purposes;
2. The publication may not be modified in any way;
3. Any copy of the publication or portion thereof must include all original copyright, trademark, and other proprietary notices and this permission statement; and
4. Cadence reserves the right to revoke this authorization at any time, and any such use shall be discontinued immediately upon written notice from Cadence.

Disclaimer: Information in this publication is subject to change without notice and does not represent a commitment on the part of Cadence. The information contained herein is the proprietary and confidential information of Cadence or its licensors, and is supplied subject to, and may be used only by Cadence's customer in accordance with, a written agreement between Cadence and its customer. Except as may be explicitly set forth in such agreement, Cadence does not make, and expressly disclaims, any representations or warranties as to the completeness, accuracy or usefulness of the information contained in this document. Cadence does not warrant that use of such information will not infringe any third party rights, nor does Cadence assume any liability for damages or costs of any kind that may result from use of such information.

Cadence is committed to using respectful language in our code and communications. We are also active in the removal and replacement of inappropriate language from existing content. This product documentation may however contain material that is no longer considered appropriate but still reflects long-standing industry terminology. Such content will be addressed at a time when the related software can be updated without end-user impact.

Restricted Rights: Use, duplication, or disclosure by the Government is subject to restrictions as set forth in FAR52.227-14 and DFAR252.227-7013 et seq. or its successor.

Contents

1

<u>Voltus-XFi Licensing Information</u>	9
---	---

<u>Voltus-XFi Release Compatibility Matrix</u>	11
--	----

2

<u>Introduction to Voltus-XFi</u>	13
---	----

<u>Voltus-XFi Flow Overview</u>	14
---------------------------------------	----

<u>Data Requirements for Voltus-XFi</u>	16
---	----

<u>Launching Voltus-XFi in the GUI Mode</u>	17
---	----

<u>Starting the Virtuoso Studio Design Environment</u>	17
--	----

<u>Starting Voltus-XFi EM-IR</u>	17
--	----

<u>Getting Familiar with the Interface</u>	19
--	----

<u>Task Pane</u>	20
------------------------	----

<u>Menus</u>	21
--------------------	----

<u>Toolbar</u>	25
----------------------	----

<u>Main Window</u>	25
--------------------------	----

<u>Voltus-XFi Log Viewer</u>	26
------------------------------------	----

3

<u>Setting Up and Running EM-IR Analysis</u>	27
--	----

<u>Specifying EM-IR Project Settings</u>	27
--	----

<u>Specifying Custom Foundry and Node Information</u>	30
---	----

<u>Specifying EM Rule Settings</u>	32
--	----

<u>Specifying Power Nets for EM-IR Analysis</u>	34
---	----

<u>Specifying Parasitic Extraction Settings</u>	37
---	----

<u>Setting Up an Extraction Job Policy</u>	38
--	----

<u>Editing a Job Policy</u>	39
-----------------------------------	----

<u>Deleting a Job Policy</u>	39
------------------------------------	----

<u>Using an Existing DSPF File</u>	40
--	----

<u>Using an Existing CCL File</u>	42
---	----

Voltus-XFi Custom Power Integrity Solution User Guide

Specifying New Extraction Settings	44
Specifying Advanced Extraction Settings	48
Specifying Simulation Settings	52
Performing Dynamic Analysis	53
Performing IR Analysis for LDOs, Voltage Regulators, and Generators	59
Performing Static Power Grid Solver Analysis	62
Performing Static Analysis	66
Running Post Layout Simulation	70
Generating a DSPF	71
Running EM-IR Analysis	73
Running DSPF Linter on a DSPF Netlist File	76

4

Viewing EM-IR Analysis Results	79
Working with History Items	84
Rerunning EM Analysis with Different EM Settings	87
The Voltus-XFi Results Browser Graphical User Interface	88
Customizing Data Loading of EM-IR Analysis Results	96
Displaying and Hiding Voltus-XFi Results Browser	101
Visualizing EM-IR Analysis Results using Voltus-XFi Results Browser	102
Querying Specific Areas and Shapes in the Layout for Node/Resistor Information	106
Performing LRP Analysis	108
Shorting Layers for LRP Analysis	110
Selecting a Node for LRP Analysis from the IR Tab	112
Viewing Detailed Electromigration Information	113
Viewing the Thermal Delta-T Plots	115
Customizing the Range for Viewing Violations	118
Loading and Viewing Nets from a Power Gate Group	124
Viewing EM-IR Analysis Reports	126
Summary Report	128
IR Report	130
EM Report	131
Unmatched Resistor Report	132
Pin Current Report	133
Viewing Waveform Results	134

5

Environment Variables	135
<u>ambientTemp</u>	135
<u>blockingDeviceFile</u>	135
<u>compressDSPF</u>	136
<u>cornerName</u>	136
<u>customFoundrySetupDir</u>	137
<u>dataSource</u>	137
<u>deltaTemp</u>	138
<u>designResistorFile</u>	138
<u>designResistorUnit</u>	139
<u>dfllayerMapFile</u>	139
<u>dspfNetListExtraPort</u>	140
<u>dynamicAnalysisOptionsFile</u>	140
<u>emRuleFile</u>	141
<u>enableBalloon</u>	141
<u>enableFIT</u>	141
<u>enableSmallerPrecision</u>	142
<u>enableViolationColoring</u>	142
<u>enableHeatSink</u>	143
<u>enableSHE</u>	143
<u>extractionDir</u>	144
<u>extractionMode</u>	144
<u>foundry</u>	145
<u>fractureViaCount</u>	145
.....	145
<u>includetCmdFile</u>	145
<u>lifeTime</u>	146
<u>loadResultsSettingsFile</u>	146
<u>lvsSource</u>	147
<u>modeFit</u>	147
<u>modeSHE</u>	148
<u>node</u>	148
<u>paramFileFit</u>	149
<u>paramFileSHE</u>	149

Voltus-XFi Custom Power Integrity Solution User Guide

<u>pinOrderFile</u>	150
<u>productLife</u>	150
<u>projectDir</u>	151
<u>qrcTechFile</u>	151
<u>RCType</u>	151
<u>rciRCXFile</u>	152
<u>signalNetsIRFile</u>	152
<u>simulationDir</u>	153
<u>techDir</u>	153
<u>techLibraryFile</u>	154
<u>techName</u>	154
<u>temp</u>	155
<u>tileXSHE</u>	155
<u>tileYSHE</u>	155
<u>useSeparateDirs</u>	156
<u>useTempCoeff</u>	156
<u>viaArrayCount</u>	157
<u>viaArraySpacing</u>	157
<u>uriModelFile</u>	158

6

<u>Voltus-XFi EM-IR Form Description</u>	159
<u>Voltus-XFi EM-IR GUI – Setup Tab</u>	159
<u>Voltus-XFi EM-IR GUI – Run Tab</u>	174
<u>Voltus-XFi EM-IR GUI – Results Tab</u>	175
<u>Voltus-XFi EM-IR GUI – Diagnostic Tools Tab</u>	175

7

<u>SKILL Functions</u>	177
<u>vxfiLoadNets</u>	178
<u>vxfiLoadEMIRResults</u>	179
<u>vxfiOpenLayout</u>	180
<u>vxfiSaveNetSummaryInfoToCSV</u>	181
<u>vxfiSessionConnect</u>	182
<u>vxfiSessionRegisterCreationCallback</u>	184

Voltus-XFi Custom Power Integrity Solution User Guide

<u>vxfiSetLVQueryOutputDirectory</u>	185
<u>vxfiSetLVSRunName</u>	186

Voltus-XFi Custom Power Integrity Solution User Guide

Voltus-XFi Licensing Information

You need the following licenses to run Voltus-XFi Custom Power Integrity Solution:

License	License Number	Description
Virtuoso Framework License (running Voltus-XFi in the GUI mode requires checkout availability of the following license sets)		
Cadence Design Framework II (DFII)	111	This license must be checked out at Virtuoso startup.
Virtuoso Analog Design Environment (ADE) Assembler	95250	Voltus-XFi first looks for the Virtuoso ADE Assembler license. When the ADE Assembler license is not available, a Virtuoso ADE Explorer license is checked out.
Virtuoso Analog Design Environment Explorer	95260	
Simulator License		
Spectre X Simulator	91055	Spectre X Simulator is a high performance parallel SPICE simulator with an advanced next generation circuit matrix solver and device and parasitic modeling capabilities, and new simulation presets, accelerating simulation on single core hardware. It is targeted at analog, mixed-signal, and custom IC designs with large numbers of transistors and parasitics.
Spectre Power	91400	The Spectre Power option enables EMIR analysis with the Spectre X base product.
Voltus-XFi License		

Voltus-XFi Custom Power Integrity Solution User Guide

Voltus-XFi Licensing Information

License	License Number	Description
Voltus-XFi Custom Power Integrity Solution	VTS1000	<p>Performs electromigration and voltage drop (EM-IR) analysis of power and signal nets.</p> <p>The license includes the following two features:</p> <ul style="list-style-type: none"> ■ Voltus_XFi_Cockpit: This license feature is checked out when Voltus-XFi window or Results Browser assistant is displayed. You can open multiple Voltus-XFi windows, in a single session, with a single license of VTS1000. ■ Voltus_XFi_Analysis: This license feature is checked out when EM-IR report generation is invoked. While you can have multiple Voltus-XFi windows open, this license is required for each EM-IR analysis. <p><i>Important</i></p> <p>Voltus_XFi_Analysis license is backward compatible to the Voltus-Fi XL (VTS500) and Voltus-Fi L (VTS 400) licenses. This means that the Voltus_XFi_Analysis license feature can run Voltus_Power_Integrity_Fi_XL or Voltus_Power_Integrity_Fi_L license.</p>
Quantus License		
Cadence Quantus Extraction-XL	QTS300	This license option enables both cell-level and transistor-level extraction capabilities.

Related Topics

- [Voltus-XFi Release Compatibility Matrix](#)

Voltus-XFi Release Compatibility Matrix

The table below lists the compatible versions of different products that are required to run the flow. It is recommended that you use these versions to avoid any erroneous results.

Compatible Release	Version ID
Virtuoso	IC23.1-64b.RTM
SPECTRE	21.1 ISR18
Quantus	22.1x

Related Topics

- [Voltus-XFi Licensing Information](#)

Voltus-XFi Custom Power Integrity Solution User Guide
Voltus-XFi Licensing Information

Introduction to Voltus-XFi

Voltus-XFi Custom Power Integrity Solution is used for transistor-level power and signal integrity analysis, which includes multi-mode simulation (MMSIM) for electromigration (EM) and voltage drop (IR) analysis. The target designs include large analog, mixed-signal, and custom digital blocks created in Virtuoso Studio Design Environment. Voltus-XFi provides designers with a single, unified cockpit for parasitic extraction (using Quantus), simulation (using ADE and Spectre X), and EM-IR analysis.

The salient features of Voltus-XFi are:

- An intuitive workflow-based GUI to setup and run extraction, simulation, and analysis.
- A tabbed interface that allows users to seamlessly switch between different applications.
- Ability to create the Virtuoso tungsten cell view to store the EM-IR extraction and simulation setup.
- Reuse of existing ADE maestro views to drive simulation. Voltus-XFi does not write to ADE maestro views.
- Integrated with the Spectre X simulator to analyze large post-layout netlists with high fidelity.
- An intuitive preset-based, iterative use model to allow performance versus accuracy trade-offs.
- A persistent database to store EM-IR results, optimized for loading and viewing results in Virtuoso Layout.
- An integrated Results Browser assistant to analyze and debug results directly on the Virtuoso layout.

Related Topics

- [Setting Up and Running EM-IR Analysis](#)
- [Voltus-XFi Flow Overview](#)

Voltus-XFi Flow Overview

The flow of the Voltus-XFi EM-IR solution is represented in the following diagram:

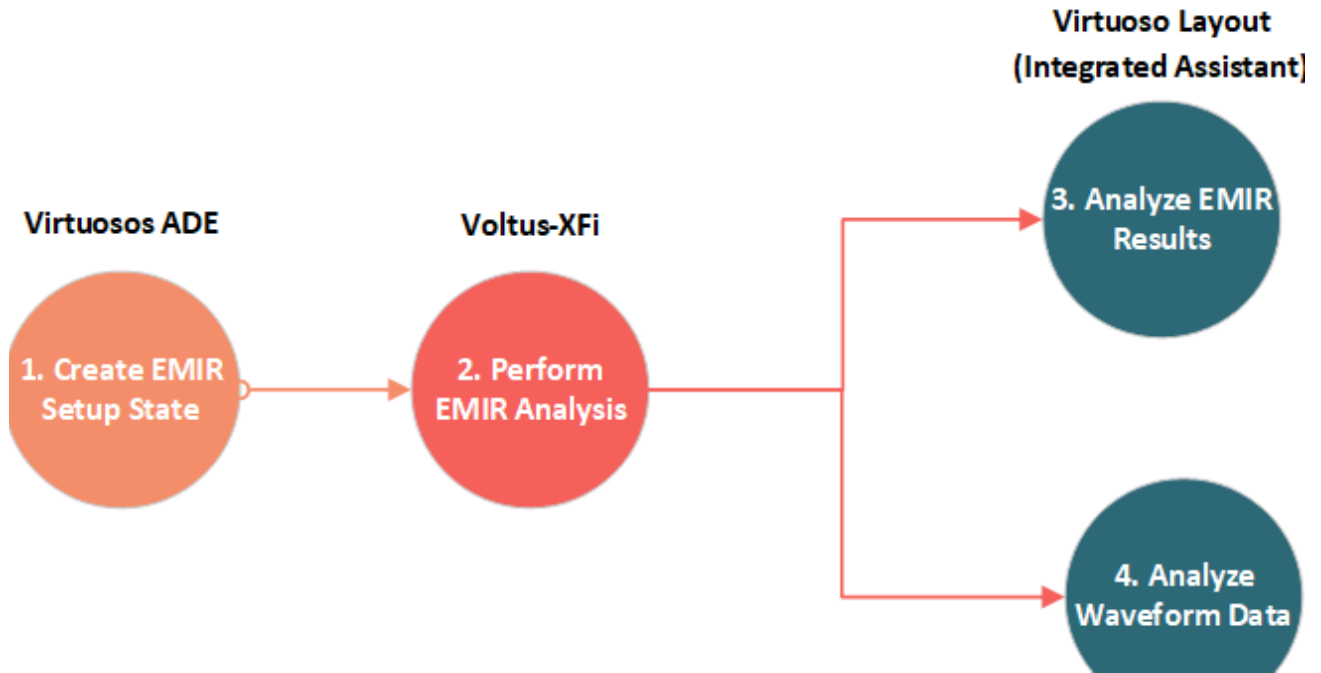

The following table describes the steps of the Voltus-XFi workflow:

Workflow Step	Description
In Virtuoso ADE Assembler, create an EM-IR setup state.	<ul style="list-style-type: none"> ■ Create a simulation testbench. ■ Set up simulation corners. ■ Save an EM-IR setup state.

Voltus-XFi Custom Power Integrity Solution User Guide

Introduction to Voltus-XFi

Workflow Step	Description
Perform EM-IR analysis in Voltus-XFi.	<ul style="list-style-type: none">■ Generate xDSPF using Quantus or point to an existing xDSPF.■ Import the simulation setup state or active setup.■ Specify EM-IR analysis to run Power IR/EM analysis and Signal IR/EM analysis.■ Run the static, dynamic, and static power grid solver (SPGS) analyses and generate text reports and results database.
Load EM-IR results in Voltus-XFi Results Browser.	<ul style="list-style-type: none">■ Analyze IR drop, electromigration, SPGS, and least-resistive path (LRP) analysis results directly on the Virtuoso layout.■ Run region-based queries.■ Debug regions of high IR drop and/or EM violation.
Analyze waveform data.	<ul style="list-style-type: none">■ Display current and voltage waveforms in VIVA Waveform Viewer.

Related Topics

- [Setting Up and Running EM-IR Analysis](#)
- [Viewing EM-IR Analysis Results](#)

Data Requirements for Voltus-XFi

The following diagram illustrates the inputs required for EM-IR analysis in Voltus-XFi:

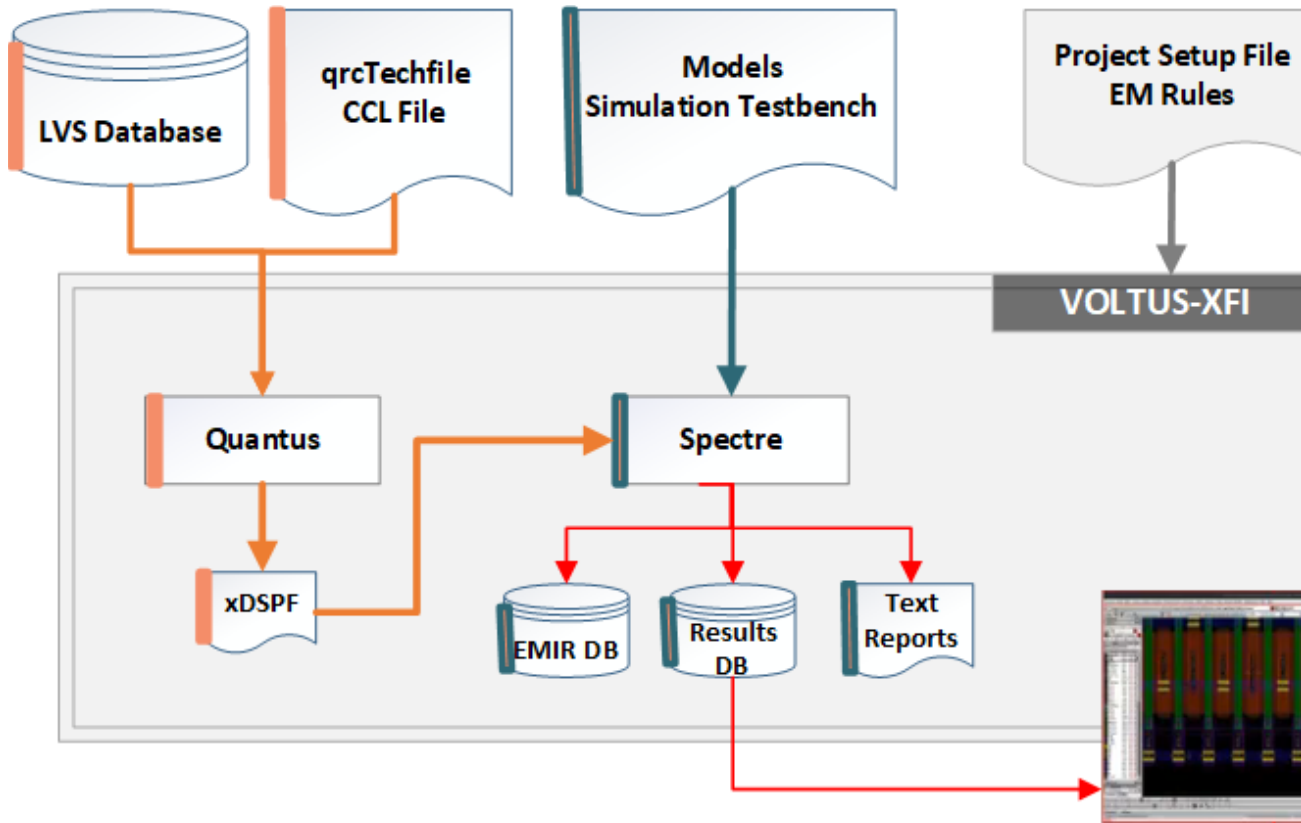

The following inputs are required for EM-IR analysis in Voltus-XFi:

- xDSPF – parasitic netlist of the design
- EM Rules
- Power and Signal Nets
- Type of analysis to be performed (peak, avg, rms, absAvg)

Related Topics

- [Setting Up and Running EM-IR Analysis](#)
- [Viewing EM-IR Analysis Results](#)
- [Voltus-XFi Flow Overview](#)

Launching Voltus-XFi in the GUI Mode

The flow to run the Voltus-XFi EM-IR solution in the GUI mode comprises the following steps:

1. [Starting the Virtuoso Studio Design Environment](#)
2. [Starting Voltus-XFi EM-IR](#)

Starting the Virtuoso Studio Design Environment

To start the Virtuoso Studio design environment, do the following:

- Type `virtuoso &` in the UNIX window, shell, or xterm.

The Command Interpreter Window (CIW) opens. You can now interact with the design environment from the CIW.

Starting Voltus-XFi EM-IR

To start Voltus-XFi, do one of the following:

Create a new Tungsten view.	<ol style="list-style-type: none">1. In the CIW, choose <i>File – New – Cellview</i>. The New File form opens.2. In the <i>Library</i> field, select a library.3. In the <i>Cell</i> field, type a new or existing cell name.4. In the <i>Type</i> field, select <i>tungsten</i>.5. In the <i>View</i> field, type a name for your cellview. The default view name is <i>tungsten</i>.6. Ensure that <i>Voltus-XFi</i> is selected in the <i>Open with</i> drop-down list.7. Click <i>OK</i>. <p>The <i>tungsten</i> view will open in Voltus-XFi. The <i>tungsten</i> view stores all settings related to running Voltus-XFi EM/IR analysis.</p>
-----------------------------	---

Open an existing Tungsten view . To do this, use either the *File* menu or the *Tools* menu of the CIW.

File Menu of CIW

1. Choose *File – Open*.

The Open File form opens.

2. In the *File* group box, select a *Library*, select a cell name from the *Cells* list or directly type the cell name in the *Cell* field, and select a *View (tungsten)*.

Alternatively, you can click *Browse* to open the Library Browser – Open File window and select your design.

3. Select one of the *Open for* options: *edit* or *read*.
4. Click *OK*.

Tools Menu of CIW

1. Choose *Tools – Library Manager*.

The Library Manager form opens.

2. To select a library and its corresponding cell and view, click the item names in the order: *Library*, *Cell*, and *View*. Select *tungsten* in the *View* section.

3. Double-click the view.

The tungsten view will open in Voltus-XFi. The tungsten view stores all settings related to running Voltus-XFi EM/IR analysis.

Related Topics

- [Setting Up and Running EM-IR Analysis](#)
- [Viewing EM-IR Analysis Results](#)

Getting Familiar with the Interface

The Voltus-XFi UI allows designers to seamlessly switch between different tasks like setting up, running the flow, and viewing the results. The left pane facilitates navigation and the right pane displays information about the specific task.

The Welcome Screen, as shown in the following figure, is displayed on launching Voltus-XFi.

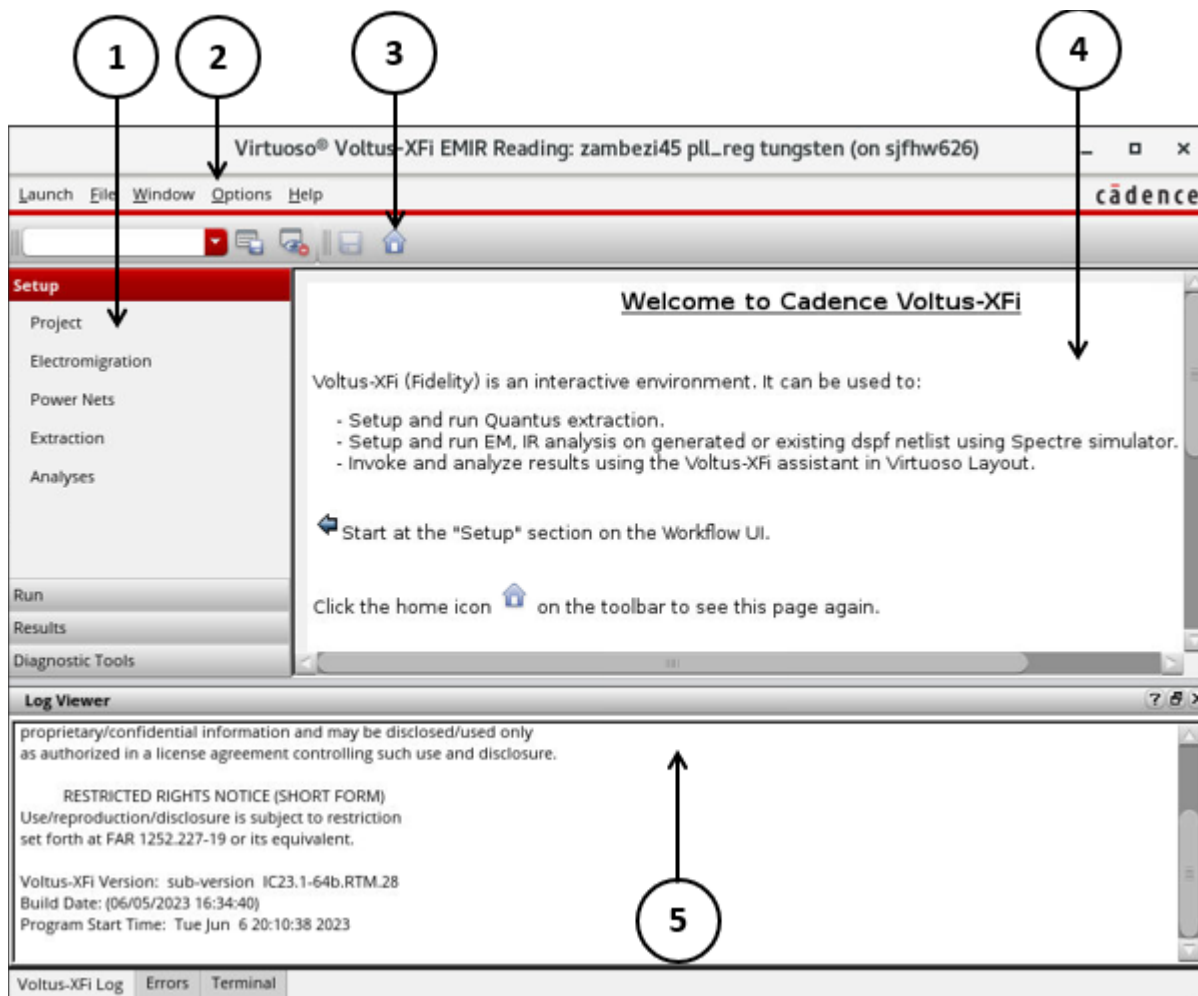

1--Task Pane

2-- Menus

3--Toolbar

4--Main Window

5--Log Viewer

Voltus-XFi Custom Power Integrity Solution User Guide

Introduction to Voltus-XFi

This display contains three main parts: a task pane on the left, which is always available; a main window on the right, whose content changes as you select items from the task pane; and a log viewer across the bottom, which displays the consolidated logs for the run. These parts are described in the following sections.

Task Pane

The task pane on the left side of the display is always present and facilitates navigation in the UI. When you first access the Voltus-XFi GUI, the *Setup* tab is selected by default.

Tab Name	Function
<i>Setup</i>	Allows to set up a project, specify power and signal nets to be analyzed, parasitic extraction, electromigration and thermal analysis settings, and simulation details.
<i>Run</i>	Allows to specify extraction and simulation setups to run.
<i>Results</i>	Allows to load IR drop and EM analysis results on the main Virtuoso layout.
<i>Diagnostic Tools</i>	A utility to ensure that the extracted DSPF file is compatible with the simulation requirements before using the file in the EM-IR flow.

Voltus-XFi Custom Power Integrity Solution User Guide

Introduction to Voltus-XFi

Menus

The following table describes the menu items for Voltus-XFi:

Menu Name	Menu Options
<i>Launch</i>	<p>Allows you to launch the following Virtuoso applications:</p> <ul style="list-style-type: none">■ <i>ADE Explorer</i>■ <i>ADE Assembler</i>■ <i>Layout XL</i>■ <i>Layout EXL</i>■ <i>Schematics L</i>■ <i>Schematics XL</i>
<i>File</i>	<ul style="list-style-type: none">■ <i>New</i> - Opens the New File form. This is the same form that appears when you choose <i>File -> New -> Cellview</i> from the CIW to create a new cellview. You must select <i>tungsten</i> from the <i>Type</i> drop-down list to create a Tungsten view.■ <i>Open</i> - Opens the Open File form to access an existing cell view.■ <i>Close</i> - Closes the Voltus-XFi application.■ <i>Save A Copy</i> - Opens the Save a Copy form so you can save a copy of the current Tungsten setup database to a different location.■ <i>Make Readable</i> - Lets you switch between read-only and edit modes.■ <i>Bookmarks</i> - Allows you to bookmark design views and return to them during the current or future sessions.■ <i>Close All</i> - Closes all active cellviews.

Voltus-XFi Custom Power Integrity Solution User Guide

Introduction to Voltus-XFi

Menu Name	Menu Options
<i>Window</i>	<ul style="list-style-type: none">■ <i>Assistants</i> - Displays or hides the selected assistant pane.■ <i>Toolbars</i> - Displays or hides the selected toolbar.■ <i>Workspaces</i> - Displays the selected workspace.■ <i>Tabs</i> - Allows you to work with tabs in the session window.
<i>Options</i>	<ul style="list-style-type: none">■ <i>Job Setup</i> - Opens <i>Voltus XFi Job Policy Editor</i>.
<i>Help</i>	<ul style="list-style-type: none">■ <i>Search</i> - A text field that lets you enter a search string. Press <i>Enter</i> to view the search results. Do not enclose the search string in double quotes.■ <i>Voltus-XFi User Guide</i> - Opens <i>Voltus-XFi User Guide</i> in Cadence Help.■ <i>Voltus-XFi What's New</i> - Opens the <i>Voltus-XFi What's New</i> document in Cadence Help.■ <i>Voltus-XFi Known Problems and Solutions</i> - Opens the <i>Voltus-XFi Known Problems and Solutions</i> document in Cadence Help.

Voltus-XFi Custom Power Integrity Solution User Guide

Introduction to Voltus-XFi

Menu Name	Menu Options
	<ul style="list-style-type: none"> ■ <i>Virtuoso Documentation Library</i> - Opens the Cadence Help home page, which provides quick access links to the following local and online resources: <ul style="list-style-type: none"> □ What's New □ Video Demos and Tutorials □ Featured Content □ Known Problems and Solutions □ Other web resources ■ <i>Virtuoso Video Library</i> - Opens the Video Library page available on Cadence Online Support (COS). This page lists the videos available for various Virtuoso products. ■ <i>Virtuoso Rapid Adoption Kits</i> - Opens the Rapid Adoption Kits page on COS. This page lists Rapid Adoption Kits (RAKs) available for various Virtuoso products. A RAK contains design databases and instructions on how to run the design flow. ■ <i>Virtuoso Learning Map</i> - Lists domain-specific trainings available on Cadence Training Services. Cadence Training Services learning maps provide a comprehensive visual overview of the learning opportunities for Cadence customers. They provide recommended course flows as well as tool experience and knowledge levels to guide customers through a complete learning plan. ■ <i>Virtuoso Custom IC Cadence Community</i> - Opens the Cadence Community - Custom IC Design web page. This page provides access to the latest blogs and discussion threads on various Virtuosos products and solutions.





Voltus-XFi Custom Power Integrity Solution User Guide

Introduction to Voltus-XFi

Menu Name	Menu Options
	<ul style="list-style-type: none"><li data-bbox="626 363 1443 695">■ <i>Cadence Online Support</i> - Opens COS, which you can use to access information about Cadence products, documentation, videos, RAKs, application notes, troubleshooting information, alerts, and so on. Improvements are regularly made to COS to make it convenient for you to look up the information you want. We recommend that you bookmark this web site and use it as your first point of reference for any Virtuoso-related information.<li data-bbox="626 720 1443 905">■ <i>Cadence Training</i> - Opens the Cadence training web page. You can find on this page information about the training courses available in different regions. Information is available about both classroom and online courses.<li data-bbox="626 930 1443 1220">■ <i>Cadence Community</i> - Opens the Cadence Community web page. This page provides access to the latest blogs and discussion threads on various Cadence products and solutions, and EDA Industry Insights. You too can contribute to the community forum by creating a Cadence account. This gives you additional benefits such as alerts about topics of interest and access to online webinars.<li data-bbox="626 1245 1443 1354">■ <i>Cadence OS Platform Support</i> - Provides information about the current Cadence software releases and the supported platforms.<li data-bbox="626 1379 1443 1488">■ <i>Contact Us</i> - Opens the Cadence Customer Support web page, which provides customer support contact information for different regions.<li data-bbox="626 1514 1443 1589">■ <i>Cadence Home</i> - Opens the Cadence corporate web site.<li data-bbox="626 1614 1443 1690">■ <i>About Virtuoso</i> - Displays the version information for Virtuoso Studio Design Environment.

Toolbar

The Voltus-XFi toolbar has the following items:

Icon	Name	Description
	Workspaces	Lists cached workspaces in the drop-down list.
	Save Workspace	Saves a custom workspace that is based on an existing, default workspace or a new version of a default workspace.
	Toggle Assistants Visibility	Hides the Log Viewer assistant. When you click the icon again, the Log Viewer assistant appears once again in the session window.
	Save	Saves your tungsten cell view.
	Home	Displays the welcome page. This page provides an overview of Voltus-XFi and guides you through the basic setup tasks.

Main Window

The main window shows the application home page by default. When you select a task name in the left pane, the main window changes and displays the form fields for that task.

Related Topics

- [Introduction to Voltus-XFi](#)
- [Voltus-XFi Log Viewer](#)

Voltus-XFi Log Viewer

The Log Viewer assistant displays the runtime information, including all the information, warning, and error messages issued by Voltus-XFi during the current session. The Log Viewer assistant includes 3 tabs:

- *Voltus-XFi Log* - prints status or information messages that indicate progression of extraction and analysis runs. For example, during extraction, you might encounter the following short messages:

```
INFO (TUNGSTEN_MSG-1062): Started Extraction ext_1 on 2022-Jun-13  
21:51:12...
```

```
INFO (TUNGSTEN_MSG-1107): Finished Extraction ext_1 on 2022-Jun-  
13 21:52:26
```

- *Error* - displays warning or error messages pertaining to the extraction setup, analysis setup, and simulation runs. The messages are grouped under the specific run names.

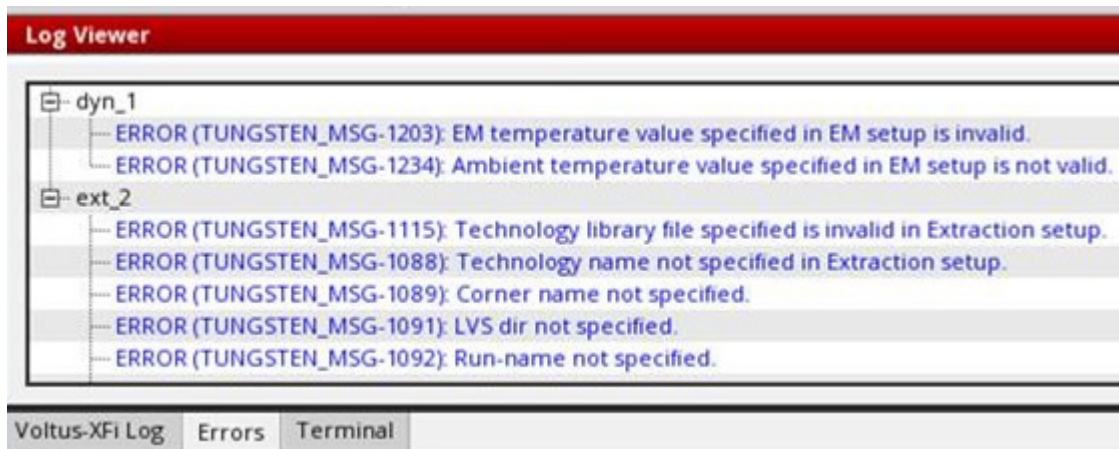

- *Terminal* - displays the integrated terminal to access the current working directory, log and result files. This can be useful as you do not have to switch windows or modify the state of an existing terminal to perform a quick command-line task.

Note: The tool also allows you to open the results directory for extraction and analysis using the *Open Terminal Here* shortcut menu option in the *Run* and *Results* tabs of the tungsten view.

Related Topics

- [Introduction to Voltus-XFi](#)
- [Getting Familiar with the Interface](#)

Setting Up and Running EM-IR Analysis

The steps for setting up and running EM-IR analysis in Voltus-XFi are detailed below.

1. [Specifying EM-IR Project Settings](#)
2. [Specifying EM Rule Settings](#)
3. [Specifying Power Nets for EM-IR Analysis](#)
4. [Specifying Parasitic Extraction Settings](#)
5. [Specifying Simulation Settings](#)
6. [Running Post Layout Simulation](#)
7. [Running EM-IR Analysis](#)

Specifying EM-IR Project Settings

Before running the EM-IR analysis, you must specify the settings for the current run. Do the following:

1. Launch Voltus-XFi.

Voltus-XFi Custom Power Integrity Solution User Guide

Setting Up and Running EM-IR Analysis

2. Choose *Setup – Project* from the task pane.

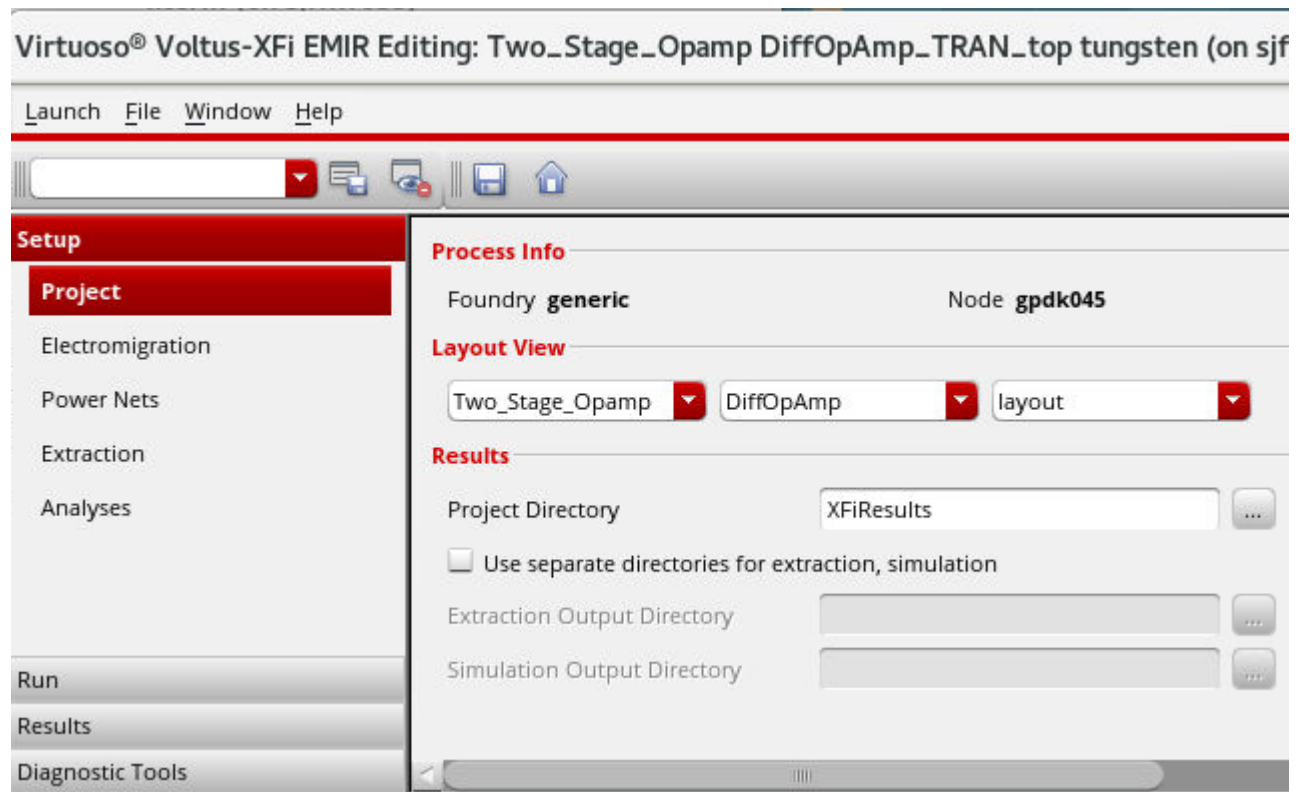

3. In the *Process Info* section, the *Foundry* and *Node* fields are disabled. The foundry and node for which you want to run EM-IR analysis need to be specified through the *foundry* and *node* .cdsenv variables.
4. In the *Layout View* section, select a library and its corresponding cell and view.
5. In the *Results* section, specify the *Project Directory* in which the results need to be saved. The default directory name is *XFiResults*. The Voltus-XFi default directory will have the following structure: *XFiResults/lib_name/cell_name/view_name*.
6. (Optional) Select the *Use separate directories for extraction, simulation* check box if you want to save the results for extraction and simulation data in separate directories.

If this check box is selected, specify the *Extraction Output Directory* and *Simulation Output Directory*, in which you want to save the extraction and simulation results, respectively.

Related Topics

- [Specifying Custom Foundry and Node Information](#)

Voltus-XFi Custom Power Integrity Solution User Guide

Setting Up and Running EM-IR Analysis

- [Launching Voltus-XFi in the GUI Mode](#)
- [Environment Variables](#)

Specifying Custom Foundry and Node Information

Voltus-XFi allows you to specify custom foundry and node details. To specify these details:

1. Run the `generate_setup_files.py` script located at: `$ <IC installation>/share/dfII/voltusXFi/bin/` as shown below:

```
$  
<IC_installation>/share/dfII/voltusXFi/bin/generate_setup_files  
.PY
```

The Voltus-XFi Custom Foundry Setup Tool appears.

2. Specify the foundry name and press *Enter*.
3. Specify the node name and press *Enter*.
4. Specify the directory path where the setup files are to be created and press *Enter*.

The custom foundry setup details are saved in a folder with the same name as the foundry.

```
Voltus-XFi Custom Foundry Setup Tool v0.1  
Enter foundry name: foundry1 Will be top folder name  
Enter node name: node1 Will be name of setup files  
Enter path to create templates: . Path to an existing directory  
Wrote setup files to /it/  
-----  
Created following setup files.  
foundry1  
├── ccl  
│   ├── base.ccl  
│   └── node1.ccl  
├── common.conf  
├── conf  
│   ├── base.conf  
│   └── node1.conf  
└── ui  
    └── node1.yaml  
  
3 directories, 6 files  
The ui/node1.yaml file controls visibility of widgets in Voltus-XFi.  
The ccl/node1.ccl can be customized to requirements.  
The ccl/base.ccl has settings needed by the Voltus-XFi. Modify only if necessary.  
The conf/node1.conf can be customized to requirements.  
The conf/base.conf has settings needed by the Voltus-XFi. Modify only if necessary.  
-----  
Add following cdsenv variables to setup  
voltusXFi.project foundry string "foundry1"  
voltusXFi.project node string "node1"  
voltusXFi.project customFoundrySetupDir string "/it/"
```

Voltus-XFi Custom Power Integrity Solution User Guide

Setting Up and Running EM-IR Analysis

5. Add the following cdsenv variables to the .cdsenv setup file:

```
voltusXFi.project foundry string "foundry_name"
```

```
voltusXFi.project node string "node_name"
```

```
voltusXFi.project customFoundrySetupDir string "directory_path"
```

If the setup is done correctly, and the cdsenv settings are updated, the new view will show the custom foundry and node names.

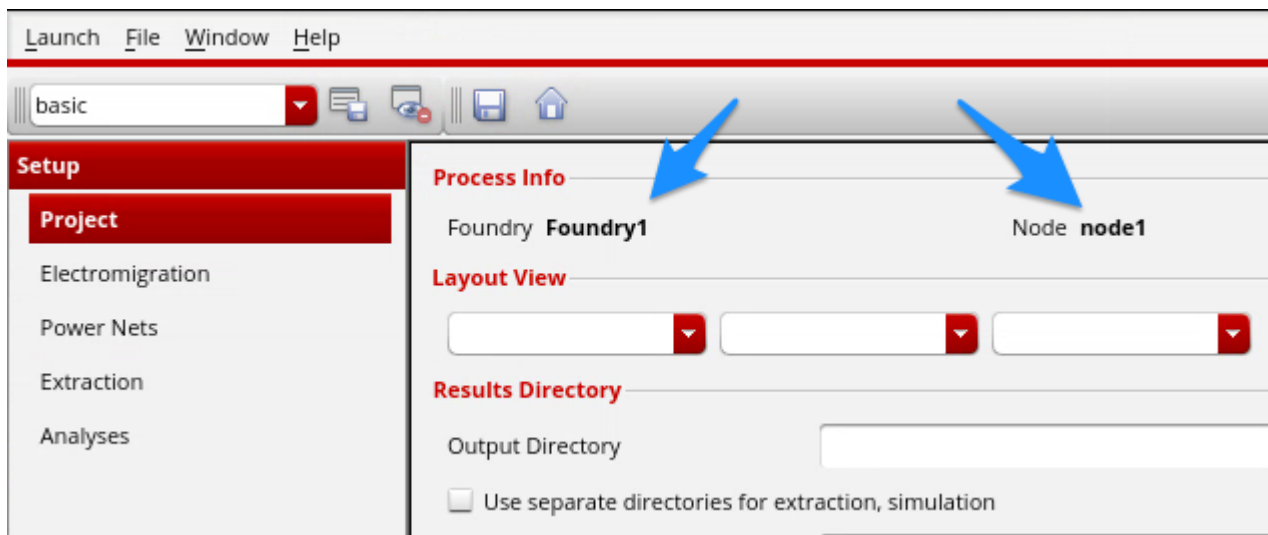

Related Topics

- [Specifying EM-IR Project Settings](#)
- [Environment Variables](#)

Specifying EM Rule Settings

To specify the EM rule settings, do the following:

1. Choose *Setup – Electromigration* from the task pane.

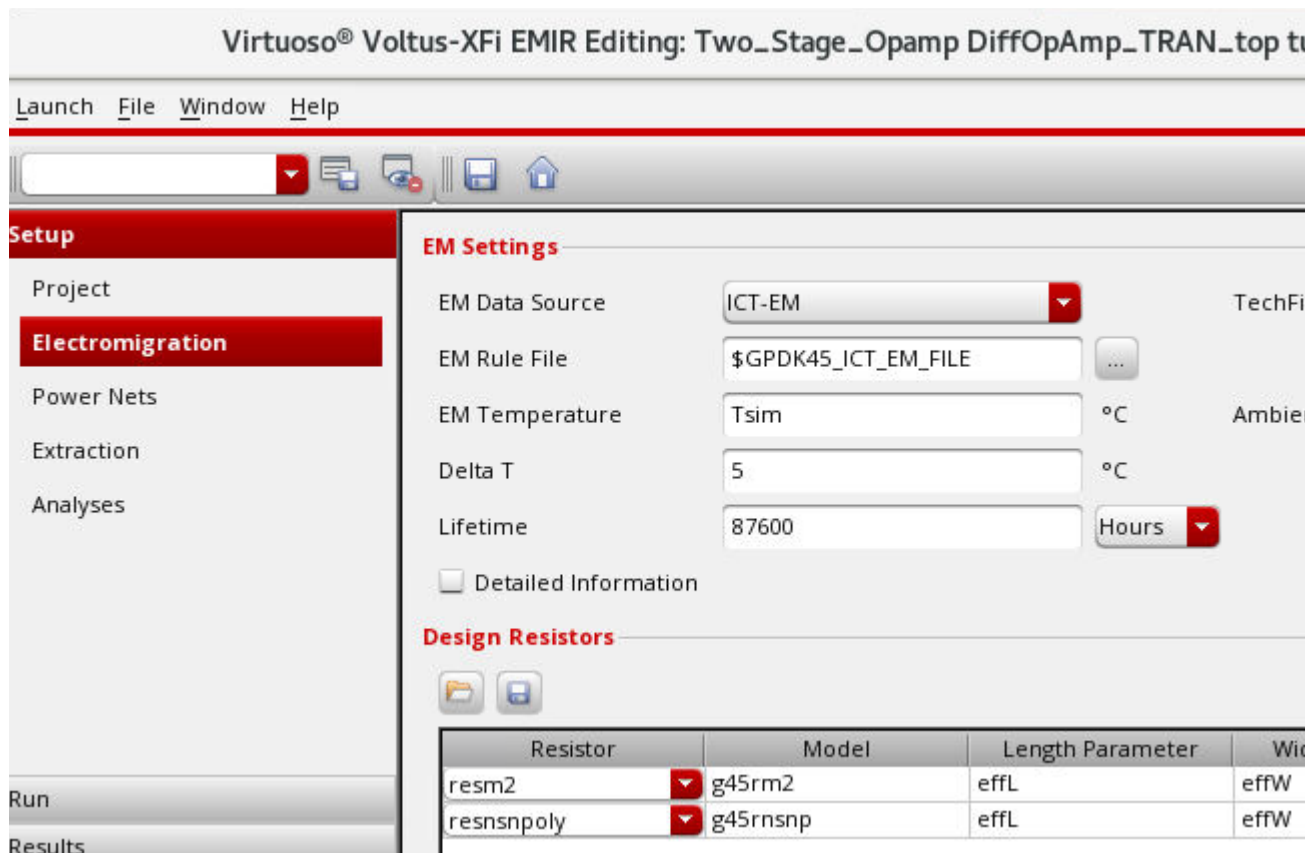

2. From the *EM Data Source* drop-down list, select the source type for electromigration rules.
3. In the *TechFile* field, specify the location of the Quantus technology file.
4. In the *EM Rule File* field, specify the location of electromigration rules file.
5. In the *EM Temperature* and *Ambient Temperature* fields, specify the temperature (in degree Celsius) at which the EM analysis and thermal analysis will be run, respectively. The default *EM Temperature* and *Ambient Temperature* is set to *Tsim* (simulation temperature).
6. (Optional) In *Delta T*, specify a value for the rise in temperature based on Joule Heating.
7. (Optional) In *Lifetime*, specify the length of time for which you want to run the EM analysis.

Voltus-XFi Custom Power Integrity Solution User Guide

Setting Up and Running EM-IR Analysis

8. (Optional) Select the *Detailed Information* check box to analyze electromigration issues in detail.

Note: Once the analysis is complete, you can select the *Detailed EM Info* option from the shortcut menu on the *EM* tab in the Voltus-XFi Results Browser to view additional information for debugging purpose.

9. (Optional) In the *Design Resistors* section, specify the design resistors you would like to include in electromigration analysis. You can either load a list of design resistors from an existing design resistor setup or add them interactively in the table.

Note: You can save the design resistor setup in a file, and then use the `designResistorFile` .cdsenv variable to load this setup automatically for a process node.

To add specific design resistors for which EM-IR analysis is be performed:

- a. Select a design resistor cell name from the *Resistor* drop-down list.
The resistor model name will be displayed in the *Model* field.
- b. Specify length and width values of the selected resistor in the *Length Parameter* and *Width Parameter* fields.
- c. Specify the layer name for the EM rule in the *Layer* field.
- d. You can select *Click to add* in the *Design Resistors* table to add more resistors.
- e. Click *Save*.

Related Topics

- [Launching Voltus-XFi in the GUI Mode](#)
- [Environment Variables](#)

Specifying Power Nets for EM-IR Analysis

To specify the power nets for EM-IR analysis, do the following:

1. Choose *Setup – Power Nets* from the task pane.
2. Select a schematic cell view and click the *Open* button.

The Schematics window opens in a new tab.

3. Select the nets in the *Navigator* pane of the Schematic window. You must select only those nets that will be in the DSPF.

The nets are automatically added to the *Power Nets* table in the Voltus-XFi window.

4. Click the tungsten tab.
5. You can select *Click to add* in the *Power Nets* table to manually add internal net names that cannot be done using schematic selection.

Voltus-XFi Custom Power Integrity Solution User Guide

Setting Up and Running EM-IR Analysis

6. Right-click a net and select an option under *Change Net(s) Type* to specify it as a global power net or a ground net.

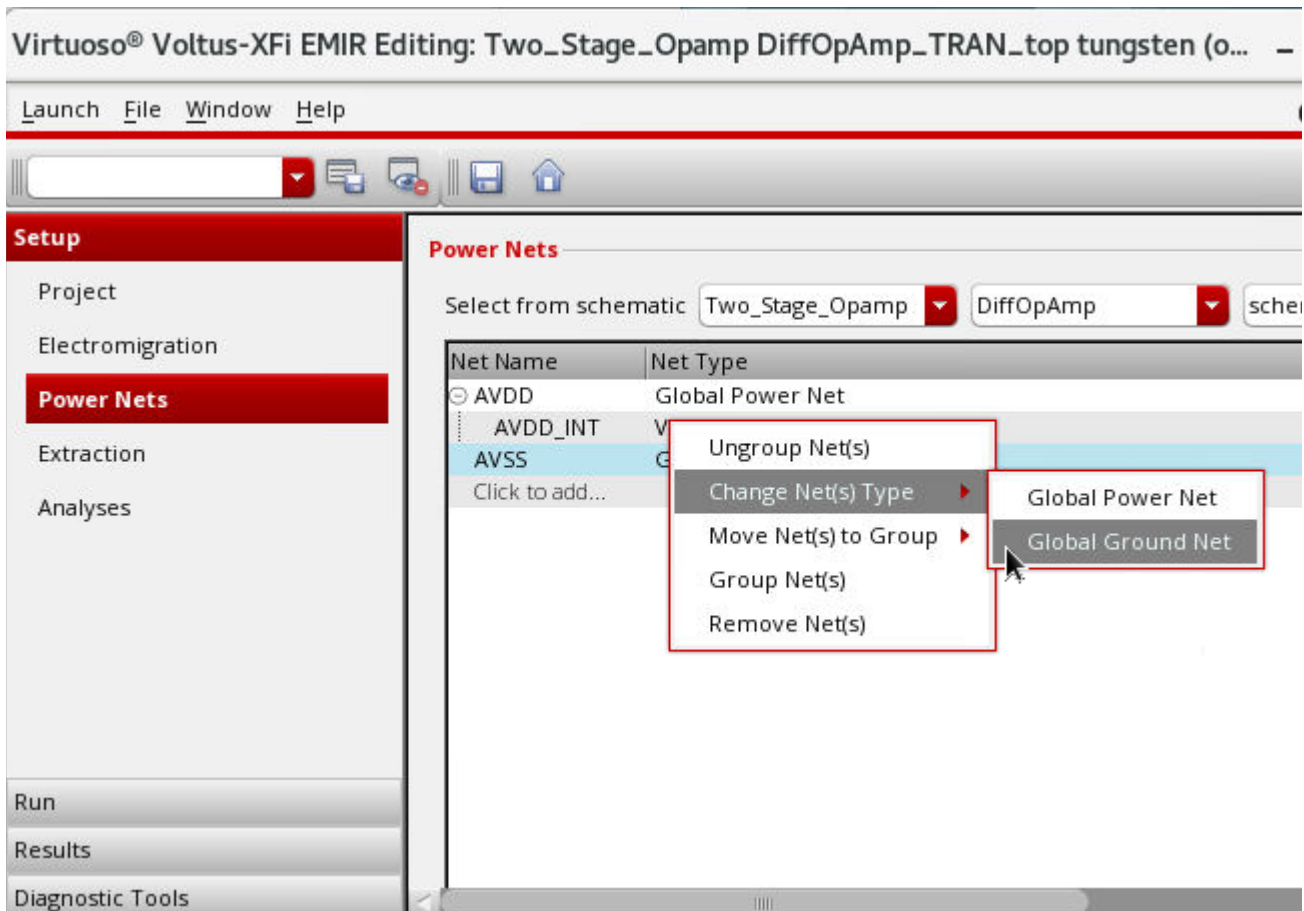

7. For power gated designs, you can select two or more nets and right-click and select *Group Nets* to create a group of virtual nets associated with a global power net. This option lets you group the global nets and its corresponding virtual nets together.

You can also use the drag-and-drop feature to easily group, ungroup, or change groups of the nets.

Related Topics

- [Launching Voltus-XFi in the GUI Mode](#)
- [Environment Variables](#)

Voltus-XFi Custom Power Integrity Solution User Guide

Setting Up and Running EM-IR Analysis

- [Voltus-XFi EM-IR Form Description](#)

Specifying Parasitic Extraction Settings

You can either point to an existing DSPF netlist or specify extraction settings to create a DSPF netlist. In addition, you can set up an extraction job policy and define the methods of how distributed processing jobs are submitted to local or remote hosts.

- [Setting Up an Extraction Job Policy](#)
- [Using an Existing DSPF File](#)
- [Using an Existing CCL File](#)
- [Specifying New Extraction Settings](#)

Related Topics

- [Launching Voltus-XFi in the GUI Mode](#)
- [Environment Variables](#)
- [Voltus-XFi EM-IR Form Description](#)

Setting Up an Extraction Job Policy

1. Choose *Options – Job Setup* from the menu bar to open the *Voltus XFi Job Policy Editor* form.

2. In the *Job Policy Name* field, specify a name for the job policy. If no job policy has been set up earlier, the *Job Policy Name* field displays *TungstenDefault* as the default job policy name.
3. From the *Distribution Method* drop-down list, choose one of the following methods:
 - Command*: To submit the extraction job to a job distribution engine.
 - Local*: To run extractions on the local host.
4. Depending upon the *Distribution Method* you selected, specify the fields described as follows:

Distribution Method	Fields	Description
<i>Command</i>	<i>Command</i>	<code>bsub</code> command to submit a job for batched execution by a distributed load-sharing batch system.
	<i>Max Jobs</i>	Maximum number of simultaneous jobs that you want to run.
<i>Local</i>	<i>Max Jobs</i>	Maximum number of simultaneous jobs that you want to run.

5. Click *Save* to save the changes.

The *Job Policy Name* drop-down list displays the name of the job policy you specified.

6. Click *OK*.

Editing a Job Policy

1. On the *Voltus XFi Job Policy Editor* form, from the *Job Policy Name* drop-down list, select the job policy that you want to edit.
2. From the *Distribution Method* drop-down list, select a distribution method.
3. Depending upon the *Distribution Method* you selected, update other fields, as required.
4. Click *Save* to save the changes.
5. Click *OK*.

Deleting a Job Policy

- In the *Voltus XFi Job Policy Editor* form, from the *Job Policy Name* drop-down list, select the job policy you want to delete, and then click *Delete*.

The selected job policy is deleted.

Related Topics

- [Specifying New Extraction Settings](#)

Using an Existing DSPF File

1. Choose *Setup – Extraction* from the task pane.
2. Click *Add Setup*.
3. In the *Name* field, specify a name for the extraction setup.
4. In the *Setup Type* section, select *Existing DSPF*, and specify the DSPF file that you want to use for EM-IR analysis.

The screenshot shows the 'Add Setup' dialog box. The 'Name' field contains 'ext_2'. Under 'Setup Type', the 'Existing DSPF' radio button is selected. The 'Run DSPF Linter' checkbox is checked. The 'Job Policy' dropdown is set to 'TungstenDefault'. The 'DSPF File' field is empty, and the 'OK' button is highlighted in red.

5. Select *Run DSPF Linter* if you want to run the spfchecker utility on DSPF.
6. Select a job policy from the *Job Policy Name* drop-down list.
7. Click *OK*.

The extraction details will be displayed in the *Extraction* tab. You can click *Add Setup* again to add additional extraction setups.

Related Topics

- [Environment Variables](#)
- [Using an Existing CCL File](#)
- [Specifying New Extraction Settings](#)

Voltus-XFi Custom Power Integrity Solution User Guide

Setting Up and Running EM-IR Analysis

- [Running DSPF Linter on a DSPF Netlist File](#)

Using an Existing CCL File

1. Choose *Setup – Extraction* from the task pane.
2. Click *Add Setup*.
3. In the *Name* field, specify a name for the extraction setup.
4. In the *Setup Type* section, select *Existing CCL*, and browse to and select the CCL file that you want to use for EM-IR analysis in the *CCL File* field.

The screenshot shows a dialog box titled "Add Setup" for configuring an "Extraction Setup". The "Name" field is filled with "ext_2". Under the "Setup Type" section, three radio buttons are present: "Existing DSPF", "Existing CCL" (which is selected and highlighted with a dashed box), and "Custom". Below this, there is a checked checkbox for "Run DSPF Linter". A "Job Policy" dropdown menu is set to "TungstenDefault". There are two empty text input fields for "CCL File" and "DSPF File", with a browse button (three dots) to the right of the "CCL File" field. At the bottom, there are four buttons: "OK" (highlighted in red), "Cancel", "Apply", and "Help".

5. Select *Run DSPF Linter* if you want to run the spfchecker utility on DSPF.
6. Select a job policy from the *Job Policy Name* drop-down list.
7. Specify the path to the DSPF file that will be generated in the *DSPF File* field.
8. Click *OK*.

The extraction details will be displayed in the *Extraction* tab. You can click *Add Setup* again to add additional extraction setups.

Related Topics

- [Environment Variables](#)

Voltus-XFi Custom Power Integrity Solution User Guide

Setting Up and Running EM-IR Analysis

- [Using an Existing DSPF File](#)
- [Specifying New Extraction Settings](#)

Specifying New Extraction Settings

1. Choose *Setup – Extraction* from the task pane.
2. Click *Add Setup*.
3. In the *Name* field, specify the name of the extraction run.
4. In the *Setup Type* section, select *Custom*.
5. Select *Run DSPF Linter* if you want to run the spfchecker utility on DSPF.
6. Select a job policy from the *Job Policy Name* drop-down list.
7. On the *Technology* tab, select either a technology library file or a technology directory from the *File/Directory* drop-down list.

The screenshot shows the 'Extraction Setup' dialog box. At the top left is an 'Add Setup' button. Below it, the 'Name' field contains 'ext_2'. The 'Setup Type' section has three radio buttons: 'Existing DSPF', 'Existing CCL', and 'Custom' (which is selected). Below this, there is a checked checkbox for 'Run DSPF Linter' and a 'Job Policy' dropdown menu set to 'TungstenDefault'. The 'Technology' tab is selected, showing a 'File/Directory' dropdown set to 'Technology Directory' and a text field containing '\$env(GPDK45_QRCTECHFILE_DIR)'. There is also a 'Temperature' section with a radio button for 'Use temperature coefficient for extracted re'. At the bottom are 'OK', 'Cancel', 'Apply', and 'Help' buttons.

8. If you select *Technology Library File*:
 - a. Browse to and select the technology library file (*pvtech.lib*).

Voltus-XFi Custom Power Integrity Solution User Guide

Setting Up and Running EM-IR Analysis

The *Technology Name* field and *Corners* table will be automatically displayed.

- b. To add the technology name and corners manually, you can type in the *Technology Name* field, and add the list of corners in the *Corners* table. Press the `Tab` key to add multiple corners and the temperature of the corners at which the extraction will be performed.
- c. Select the *Use temperature coefficient for extracted resistors* check box if you want to use the simulation temperature to compute parasitic resistance.

If you select this check box, you cannot specify the temperature for the individual corners.

9. If you select *Technology Directory*:

- a. Browse to and select the directory where Quantus technology file (*qrcTechFile*) resides.
- b. Specify the temperature at which the extraction will be performed, or select the *Use temperature coefficient for extracted resistors* check box if you want to use the simulation temperature to compute parasitic resistance.

10. On the *Input* tab, select an input data source from the *LVS Source* drop-down list.

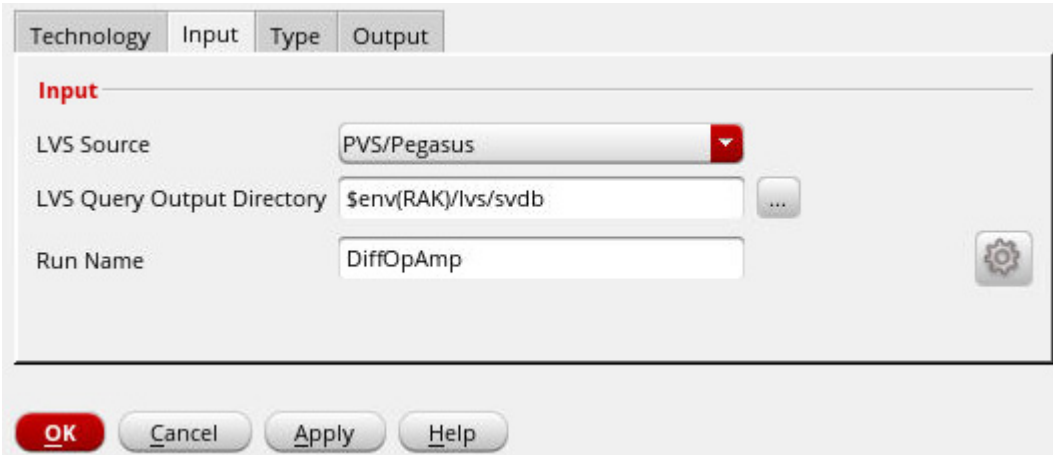

The screenshot shows a dialog box with four tabs: Technology, Input, Type, and Output. The 'Input' tab is selected. It contains three input fields: 'LVS Source' with a dropdown menu showing 'PVS/Pegasus', 'LVS Query Output Directory' with a text field containing '\$env(RAK)/lvs/svdb' and a browse button (...), and 'Run Name' with a text field containing 'DiffOpAmp' and a settings gear icon. At the bottom, there are four buttons: 'OK' (highlighted in red), 'Cancel', 'Apply', and 'Help'.

11. In the *LVS Query Output Directory* field, specify the path to the directory in which the input data is stored.

12. In the *Run Name* field, specify the name of the LVS run.

Voltus-XFi Custom Power Integrity Solution User Guide

Setting Up and Running EM-IR Analysis

13. On the *Type* tab, specify the extraction type (what to extract) and the coupling mode.

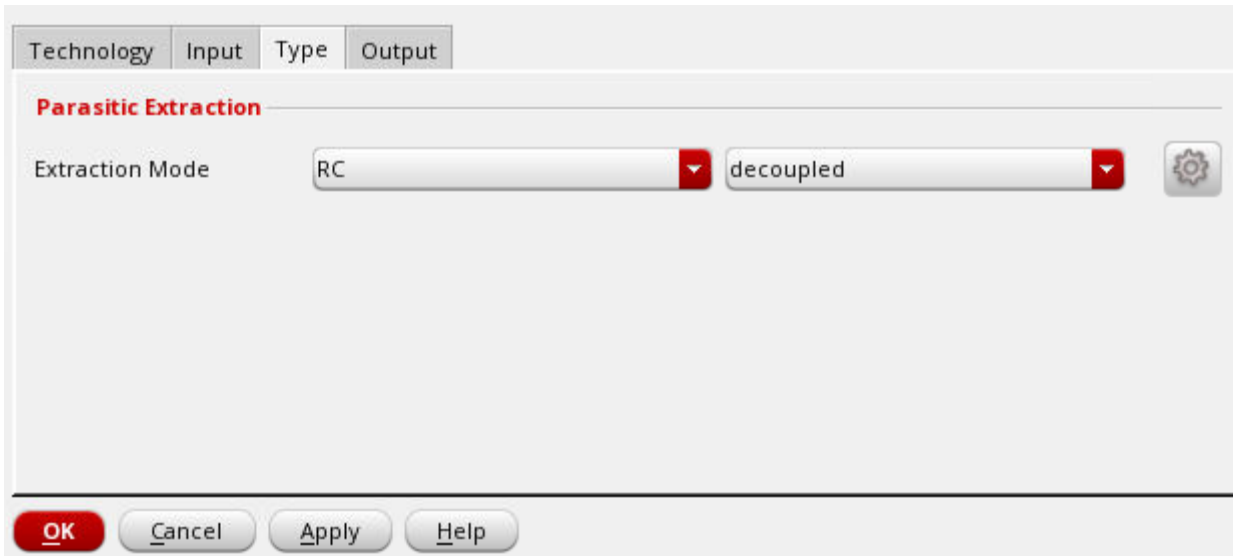

14. On the *Output* tab, specify the format of the extraction output file.

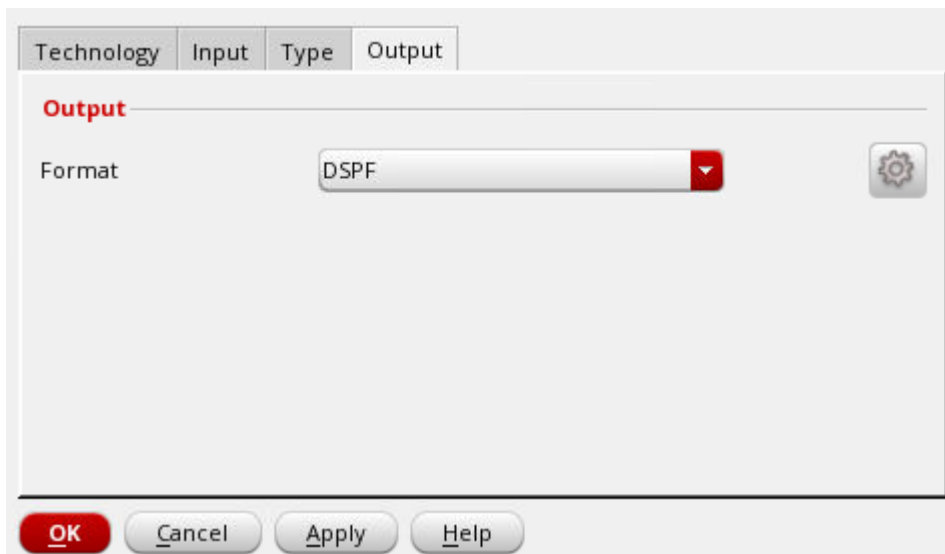

15. Click *OK*.

Voltus-XFi Custom Power Integrity Solution User Guide

Setting Up and Running EM-IR Analysis

The extraction details will be displayed in the *Extraction* tab. You can click *Add Setup* again to add additional extraction setups.

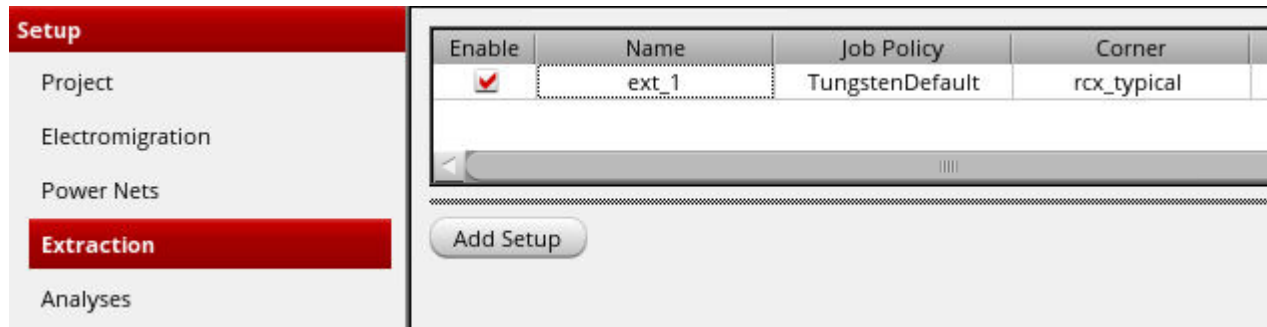

In addition to the above basic settings, you can also specify some advanced settings for extracting a netlist file.

Related Topics

- [Environment Variables](#)
- [Using an Existing DSPF File](#)
- [Using an Existing CCL File](#)
- [Specifying Advanced Extraction Settings](#)

Specifying Advanced Extraction Settings

1. In the Extraction Setup form (*Setup – Extraction* from the task pane), click the *Advanced Settings* (⚙️) icon on the *Input*, *Type*, and *Output* tabs to open the advanced settings form.
2. On the *Input* tab, specify *Pin Order File* to define the order of pins to be used during extraction.

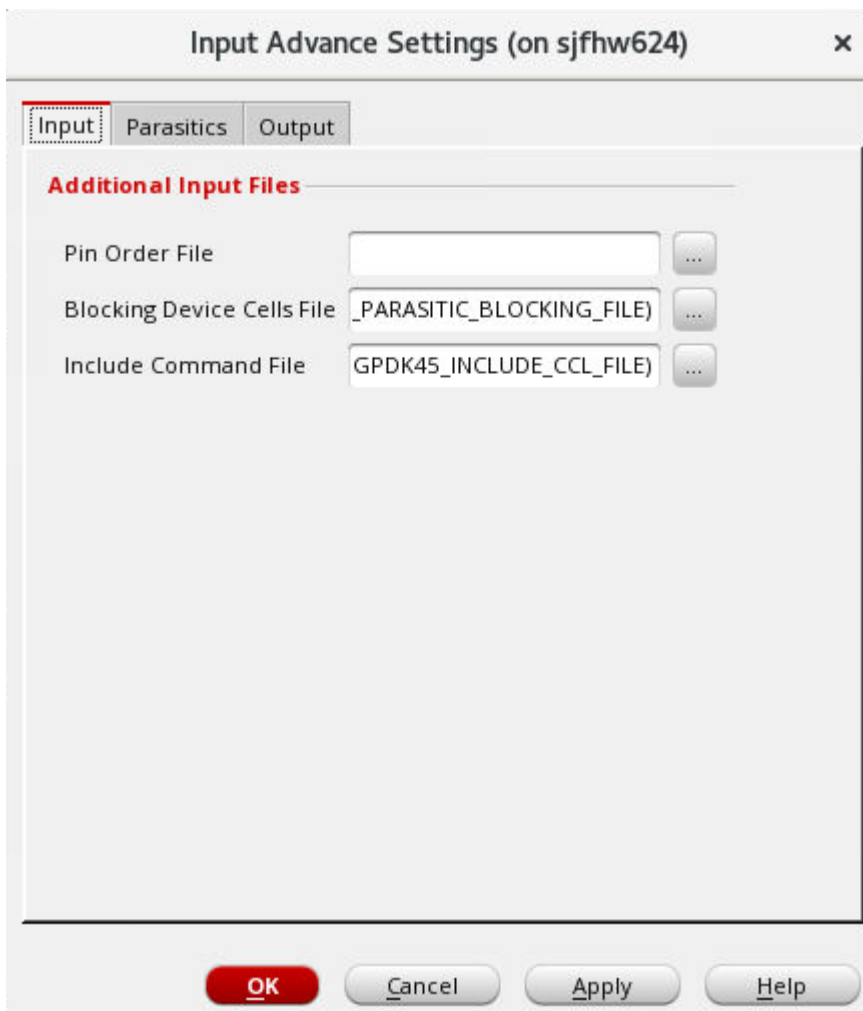

3. Specify *Blocking Device Cells File* to list the parasitic blocking device cell names.
4. Specify *Include Command File* to provide the customized extract commands.

Voltus-XFi Custom Power Integrity Solution User Guide

Setting Up and Running EM-IR Analysis

5. On the *Parasitics* tab, select either *auto* or *manual* from the *Via Array Spacing* list.

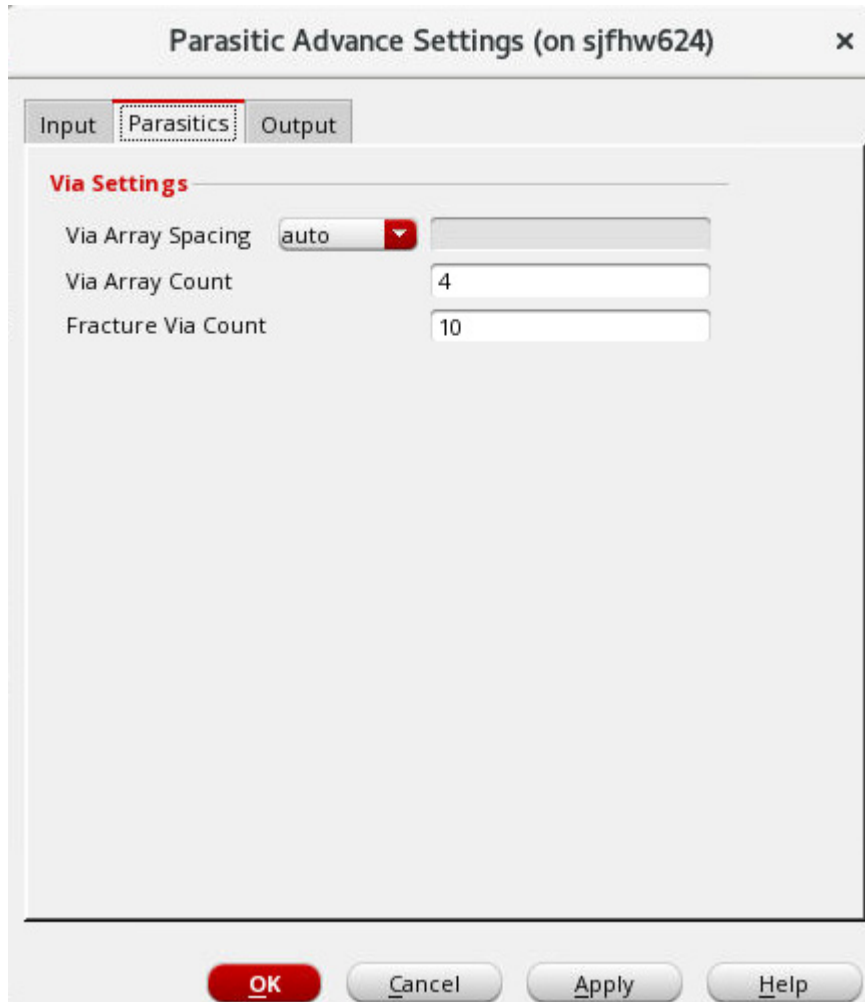

- a. If you select *auto*, the default value of the via array spacing is used.
 - b. If you select *manual*, specify the distance that will be used as the maximum distance criteria for grouping vias within the same array.
6. In the *Via Array Count* field, specify the number of vias per side allowed in an array.
 7. In the *Fracture Via Count* field, specify the number that will be used to divide the pseudo vias into segments during extraction.

Voltus-XFi Custom Power Integrity Solution User Guide

Setting Up and Running EM-IR Analysis

8. On the *Output* tab, select *Add parasitic resistor color (mask number)* if you want to enable color-aware EM analysis.

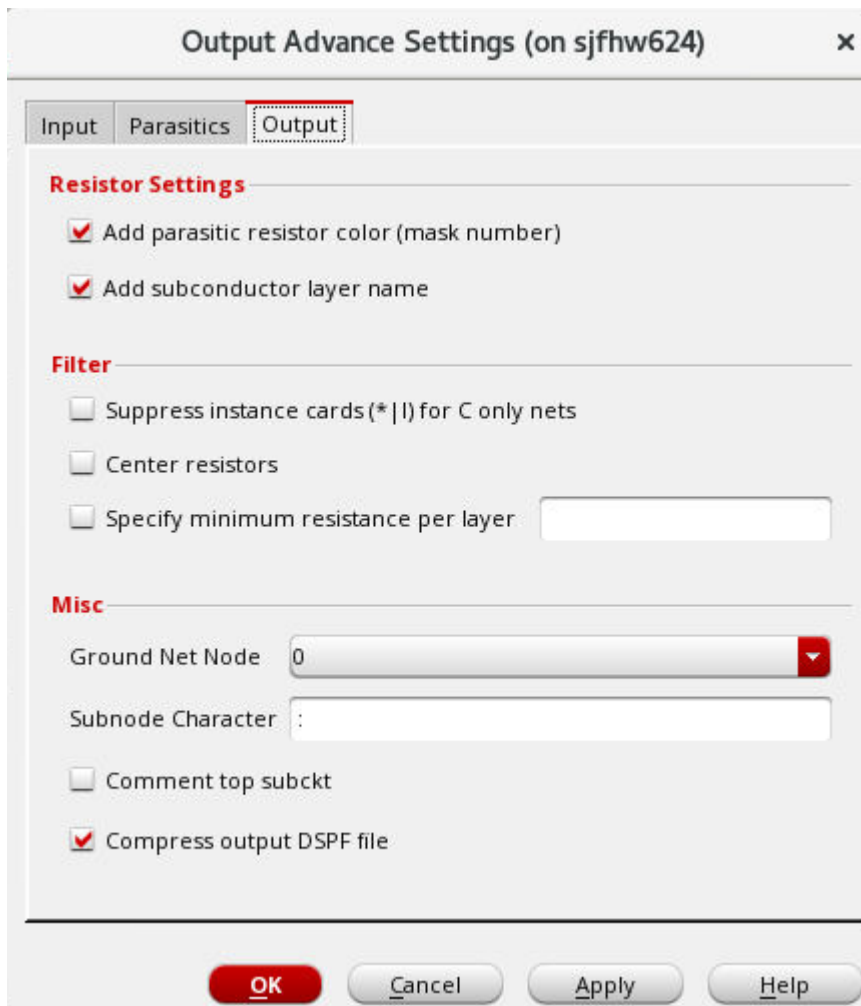

9. Select *Add subconductor layer name* if you want to include information about the parasitic resistor models for the subconductor layers.
10. Select *Suppress instance cards (*|I) for C only nets* if you do not want to print instance cards and the corresponding dummy resistors for the capacitance-only nets in the results.
11. Select *Center resistors* if you want to include sub-nodes after eliminating resistors with small resistance values.
12. Select *Specify minimum resistance per layer* and specify the LVS layer name for which the minimum resistance value for the extracted parasitic resistors is to be applied.
13. Select the reference node (net) from the *Ground Net Node* drop-down list.

Voltus-XFi Custom Power Integrity Solution User Guide

Setting Up and Running EM-IR Analysis

14. In the *Subnode Character* field, specify the subnode identification character.
15. Select *Comment top subckt* to comment out the top sub circuit statements from the DSPF file.
16. Select *Compress output DSPF File* to generate the DSPF file in a compressed format.
17. Click *OK*.

Related Topics

- [Environment Variables](#)
- [Using an Existing DSPF File](#)
- [Using an Existing CCL File](#)
- [Specifying New Extraction Settings](#)

Specifying Simulation Settings

On the *Analyses* tab, you can select the analysis that you want to run and specify the testbench information.

The following three types of analysis can be performed:

- **Dynamic Analysis** - This method can be used to evaluate IR drop and EM currents based on the results after running simulation on the design based on the testbench stimulus setup.
- **Static Power Grid Solver (SPGS) or Reflective Analysis** - This method can be used to calculate pin-to-tap resistance values. The resistance calculated by SPGS are electrically-equivalent, and not the summation of resistors. The pins on the net are connected together to form a global pin. It calculates the resistance between the global pin and all taps.
- **Static Analysis** - This method can be used to evaluate IR drop and EM currents based on the specified average current consumption of the power nets. The specified currents are distributed to the tap devices based on their size (width and length ratios or number of fins).

Related Topics

- [Performing Dynamic Analysis](#)
- [Performing Static Power Grid Solver Analysis](#)
- [Performing Static Analysis](#)

Performing Dynamic Analysis

1. Choose *Setup – Analyses* from the task pane.
2. Select *Dynamic Analysis* from the drop-down list, and click *Add Dynamic Analysis*.

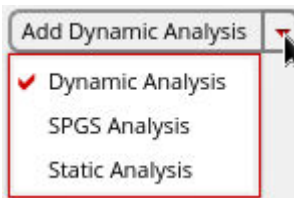

3. In the *Name* field, specify a name for the analysis setup.

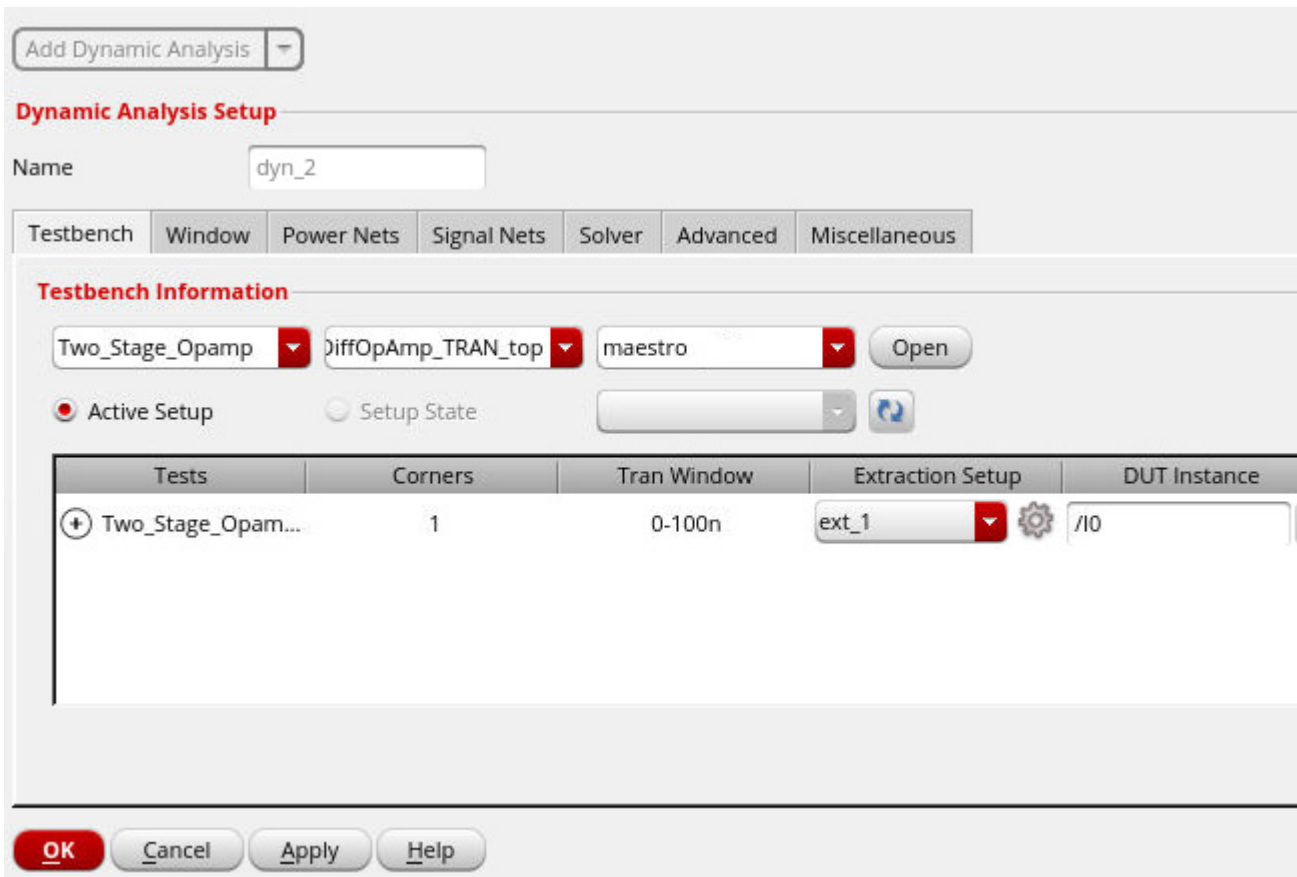

4. On the *Testbench* tab, import the testbench setup information from Virtuoso® ADE Explorer or Virtuoso® ADE Assembler.

To import the simulation setup from ADE:

Voltus-XFi Custom Power Integrity Solution User Guide

Setting Up and Running EM-IR Analysis

- a. In the *Testbench Information* section, specify the maestro cellview from which to import a testbench setup.
- b. You can view the testbench setup in ADE by clicking *Open* next to the maestro cellview.
- c. Click *Active Setup* or *Setup State* to select the testbench setup to use.

Note: The preferred use model is to create a Setup State for the EM-IR run for each block. This setup should contain the corners used for EM-IR analysis. Currently, corner groups are not supported.

- d. Click the + sign next to a test to view all the simulation corners defined for the test. You can map each simulation corner to a different extraction setup.

The *DUT instance* field will be automatically populated. If the *DUT Instance* name is not given, you can interactively select an instance from the schematic by clicking the browse button.

- e. You can click the *Advanced Settings* () icon in the *Extraction Setup* column to specify the following additional options for handling DSPF netlist.

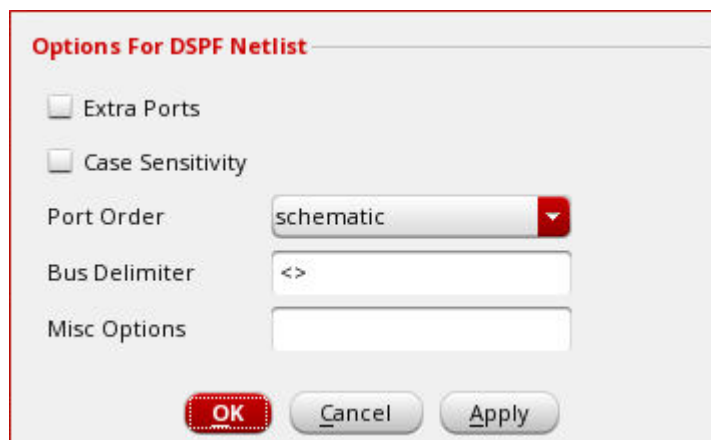

The dialog box titled "Options For DSPF Netlist" contains the following controls:

- Extra Ports
- Case Sensitivity
- Port Order: schematic (dropdown menu)
- Bus Delimiter: <> (text field)
- Misc Options: (text field)
- Buttons: OK, Cancel, Apply

- *Extra Ports* - If the port number in DSPF does not match the port number in the schematic netlist instance call, this option can be used to automatically handle extra ports. When selected, the extra ports in the DSPF subcircuit call are changed to internal nodes. In addition, the extra ports in the schematic subcircuit definition are connected to the nodes with the same name in the DSPF netlist.
- *Case Sensitivity* - Select this option to make the DSPF file case-sensitive.
- *Port Order* - Specifies whether the port order is taken from the schematic subcircuit definition or from the DSPF subcircuit definition.

Voltus-XFi Custom Power Integrity Solution User Guide

Setting Up and Running EM-IR Analysis

- *Bus Delimiter* - Defines the bus delimiter in the DSPF netlist.
 - *Misc Options* - Specifies additional options for the DSPF netlist.
5. On the *Window* tab, specify the time period for EM-IR analysis, either the full transient analysis time or a subset of the transient analysis time.

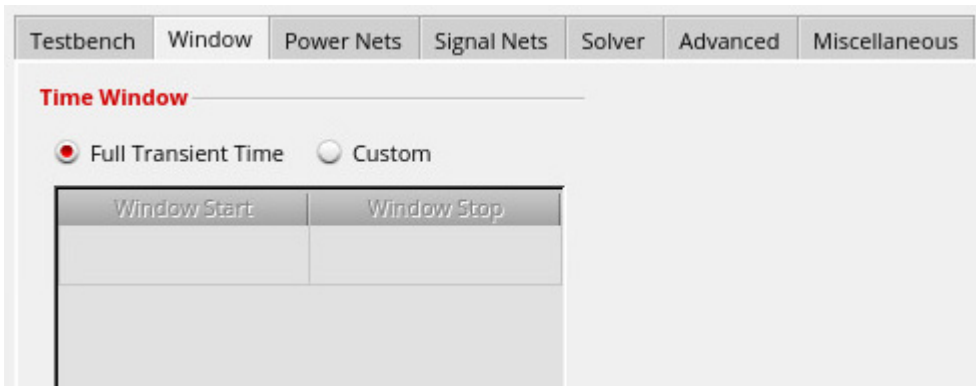

Click the *Custom* radio button to specify the subset of the transient analysis time, as shown below:

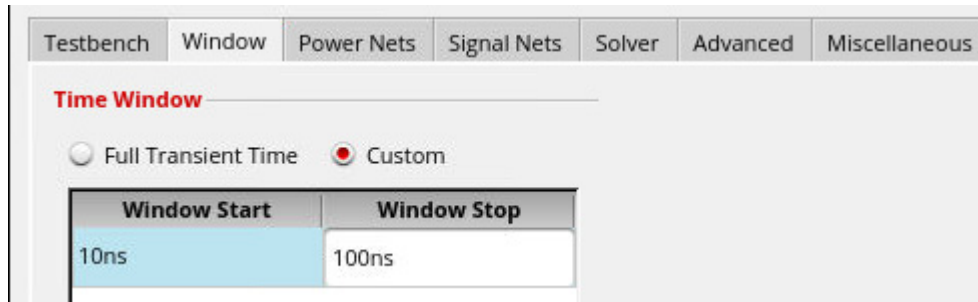

Voltus-XFi Custom Power Integrity Solution User Guide

Setting Up and Running EM-IR Analysis

- On the *Power Nets* and *Signal Nets* tabs, select the IR/EM analysis options and nets that you want to include in the analysis.

The screenshot shows the 'Power Nets' tab in the software interface. It is divided into three sections:

- IR Analysis:** Contains three checked checkboxes: 'Compute maximum IR drop (vmax)', 'Compute average IR drop (vavg)', and 'Compute peak EM violation (ipeak)'. Below these are two more checked checkboxes: 'Compute average EM violation (iavg)' and 'Compute RMS EM violation (irms)'.
- Specify Power Nets:** Contains two sub-tabs: 'Power Nets' and 'LDO Nets'. Below these is a table with two columns: 'Enable' and 'Net Name'. The table has two rows: one for 'AVDD' and one for 'AVSS', both with checked checkboxes in the 'Enable' column.

- On the *Solver* tab, specify the solver method with which the EM-IR analysis will be run and select an EM-IR preset option.

The screenshot shows the 'Solver' tab in the software interface. It contains a section titled 'Solver Settings' with two dropdown menus:

- Method:** A dropdown menu with '2-stage' selected.
- EMIR Preset:** A dropdown menu with 'mx' selected.

Voltus-XFi Custom Power Integrity Solution User Guide

Setting Up and Running EM-IR Analysis

- On the *Advanced* tab, specify the toggle net frequency and select the analysis types from the available options in the *Peak* and *Average* sections.

The screenshot shows the 'Advanced Analysis Settings' dialog box. The 'Advanced' tab is active. The 'Toggle Frequency' radio button is selected. The 'Peak' section is expanded, showing 'AC Peak Analysis (iacpeak)' and 'Dynamic AC Peak' checked. 'Single Peak' is selected. The 'Average' section is expanded, showing 'Use Recovery Factor' checked. The 'Average Absolute Current (iavgabs)' checkbox is also checked.

- On the *Miscellaneous* tab, specify the additional options for the EM-IR run and the ECO file for what-if analysis.

The *Options File* field allows you to specify a file containing the following command to generate the average current file:

```
time window=[start_time stop_time] output=power
filename=file_name.txt
```

The specified time window should not exceed the simulation stop time. The generated average current file (*file_name.txt*) will be created in the simulation directory, which

Voltus-XFi Custom Power Integrity Solution User Guide

Setting Up and Running EM-IR Analysis

can be used for static analysis. The *ECO File* option is supported only when the solver method is *2-Stage*.

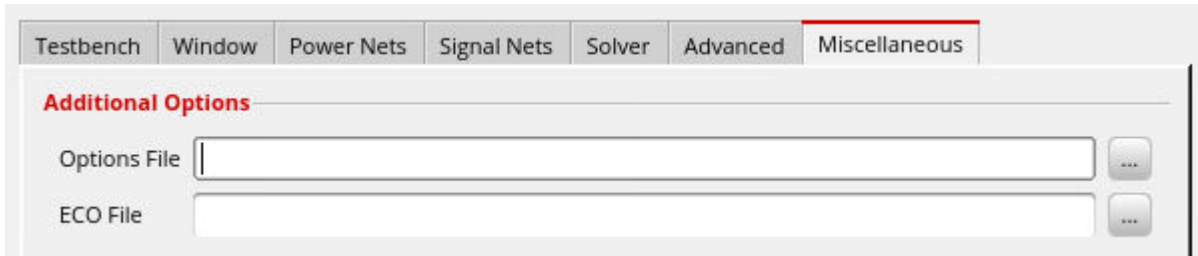

10. Click *OK*.

The analysis details will be displayed in the *Analyses* tab. You can click *Add Dynamic Analysis* again to add multiple analyses.

Related Topics

- [Voltus-XFi EM-IR GUI – Setup Tab](#)
- [Viewing EM-IR Analysis Results](#)
- [Performing Static Power Grid Solver Analysis](#)
- [Performing Static Analysis](#)
- [EMIR Control File Options](#)

Performing IR Analysis for LDOs, Voltage Regulators, and Generators

IR analysis is typically applied to power nets that are driven by constant voltage sources. However, designs may have low dropout (LDO) nets, internal generators or regulators. For these nets, IR drop analysis may be important. These nets behave like signal nets since their voltage value changes over time.

Voltus-XFi allows you to perform IR drop analysis on such nets. However, you need to define the reference voltage being used for the IR drop calculation.

To include LDO nets for a dynamic IR analysis run:

1. Choose *Setup – Analyses* from the task pane.
2. Select a dynamic analysis run for which you want to specify the LDO nets.
3. On the *Power Nets* tab, click the *LDO Nets* tab.

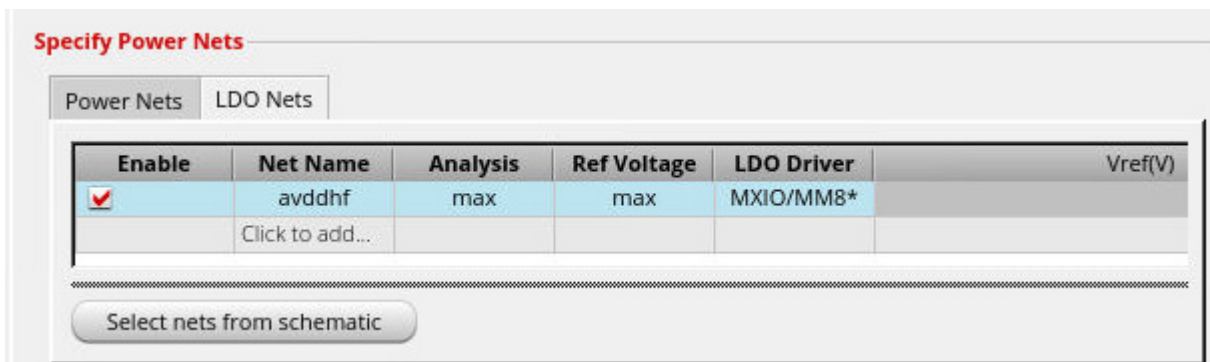

4. Select *Click to add* to manually add the LDO net names or click *Select nets from schematic* to select the nets in the schematic.
5. In this table, you can specify the following:
 - Analysis* - Compute node maximum or average IR drop compared to reference.
 - Ref Voltage* - Use either maximum voltage of all nodes at each timepoint, average voltage of all nodes at each timepoint, minimum voltage of all nodes at each timepoint, or specified voltage value as reference to calculate IR drop.
 - LDO Driver* - Use specified node of net as reference.
 - Vref* - Use the specified voltage reference value.
6. Click *OK*.

Voltus-XFi Custom Power Integrity Solution User Guide

Setting Up and Running EM-IR Analysis

To include the signal nets that are not connected to any constant voltage source for a dynamic IR analysis run:

1. Choose *Setup – Analyses* from the task pane.
2. Select a dynamic analysis run for which you want to specify the nets.
3. On the *Signal Nets* tab, click the *Signal Nets IR* tab.

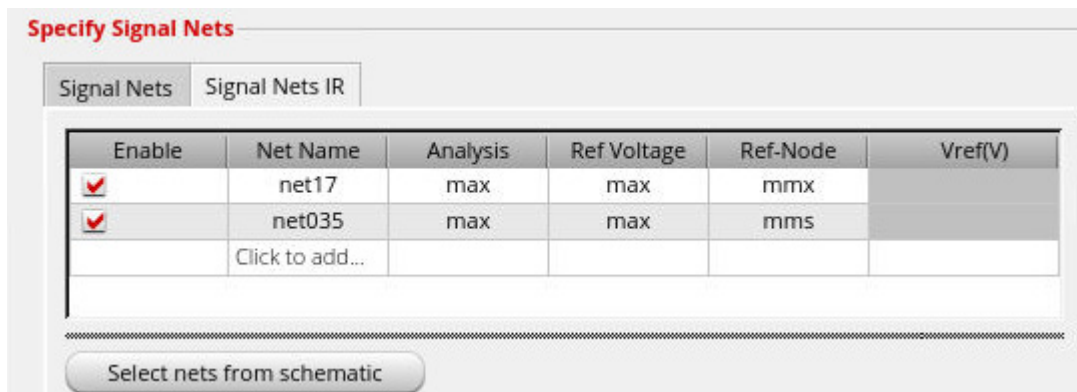

4. Select *Click to add* to manually add the net names or click *Select nets from schematic* to select the nets in the schematic.
5. In this table, you can specify the following:
 - Analysis* - Compute node maximum or node average or node absolute average IR drop compared to reference.
 - Ref Voltage* - Use either maximum voltage of all nodes at each timepoint, average voltage of all nodes at each timepoint, net pin node, or specified voltage value as reference to calculate IR drop.
 - Ref-Node* - Use specified node of net as reference.
 - Vref* - Use the specified voltage reference value.
6. Click *OK*.

When you specify the LDO and signal nets IR, these options get automatically added in the `emir.config` file.

The following is an example of the EMIR control file (`emir.config`):

```
* -----  
* LDO NETS
```

Voltus-XFi Custom Power Integrity Solution User Guide

Setting Up and Running EM-IR Analysis

```
* -----  
net name = [IO.*] analysis=[vmax]  
solver ldo_net=[IO.*] ldo_driver=[mm] ldo_vref=[max]
```

In the above example, the IR drop analysis is performed for all LDO nets `IO.*`. The node `mm` is used as reference, and the maximum voltage of all nodes at each timepoint is picked as the reference voltage.

```
* -----  
* SIGNAL NETS IR  
* -----  
net name = [IO.*] analysis=[sigvmax] reftype=max refnode=[mmx]
```

In the above example, the signal net IR drop analysis is performed for all nets `IO.*`. The maximum IR drop for the sub nodes of each net is reported. For the IR drop analysis at each net and time point, the sub node with the highest voltage is picked as the reference voltage and the reference voltage from the reference node `mmx`.

When using `reftype=[max]` for a net with three sub nodes: `net1_1` (1V), `net1_2` (2V), and `net1_3` (3V), the detected reference voltage will be 3V, and the IR drop calculated will be 2V for `net1_1`, 1V for `net1_2`, and 0V for `net1_3`. When using `reftype=[avg]` the reference voltage will be 2V, and the IR drop calculated will be 1V for `net1_1`, 0V for `net1_2`, and -1V for `net1_3`.

In addition, if `net1_2` is driven by a `vsource` and `findsrc` has been specified as yes, the voltages of `net1_2`, at all time points, will be used as the reference voltages.

Related Topics

- [Performing Dynamic Analysis](#)
- [EMIR Control File Options](#)

Performing Static Power Grid Solver Analysis

1. Choose *Setup – Analyses* from the task pane.
2. Select Static Power Grid Solver or *SPGS Analysis* from the drop-down list, and click *Add SPGS Analysis*.

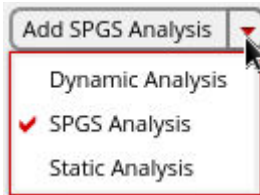

3. In the *Name* field, specify a name for the analysis setup.

Tests	Corners	Tran Window	Extraction Setup	DUT Instance
⊕ TRAN_EMIR_Dir...	2	0-30n	ext_1-rcx_typ ⚙	/I0 ...
⊕ TRAN_EMIR_Iter	2	0-30n	ext_1-rcx_typ ⚙	/I0 ...

4. On the *Testbench* tab, import the testbench setup information from Virtuoso® ADE Explorer or Virtuoso® ADE Assembler.

Voltus-XFi Custom Power Integrity Solution User Guide

Setting Up and Running EM-IR Analysis

To import the simulation setup from ADE:

- a. In the *Testbench Information* section, specify the maestro cellview from which to import a testbench setup.
- b. You can view the testbench setup in ADE by clicking *Open* next to the maestro cellview.
- c. Click *Active Setup* or *Setup State* to select the testbench setup to use.

Note: The preferred use model is to create a Setup State for the EM-IR run for each block. This setup should contain the corners used for EM-IR analysis. Currently, corner groups are not supported.

- d. Click the + sign next to a test to view all the simulation corners defined for the test. You can map each simulation corner to a different extraction setup.

The *DUT instance* field will be automatically populated. If the *DUT Instance* name is not given, you can interactively select an instance from the schematic by clicking the browse button.

- e. You can click the *Advanced Settings* () icon in the *Extraction Setup* column to specify the following additional options for handling DSPF netlist.

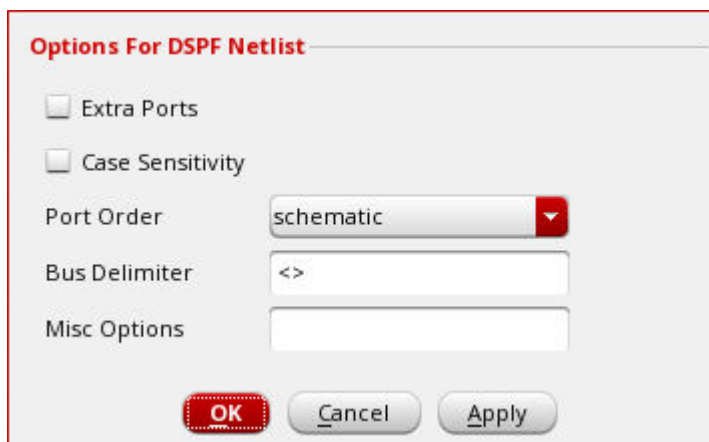

The dialog box titled "Options For DSPF Netlist" contains the following controls:

- Extra Ports
- Case Sensitivity
- Port Order: schematic (dropdown menu)
- Bus Delimiter: <> (text field)
- Misc Options: (empty text field)
- Buttons: OK, Cancel, Apply

- *Extra Ports* - If the port number in DSPF does not match the port number in the schematic netlist instance call, this option can be used to automatically handle extra ports. When selected, the extra ports in the DSPF subcircuit call are changed to internal nodes. In addition, the extra ports in the schematic subcircuit definition are connected to the nodes with the same name in the DSPF netlist.
- *Case Sensitivity* - Select this option to make the DSPF file case-sensitive.

Voltus-XFi Custom Power Integrity Solution User Guide

Setting Up and Running EM-IR Analysis

- *Port Order* - Specifies whether the port order is taken from the schematic subcircuit definition or from the DSPF subcircuit definition.
- *Bus Delimiter* - Defines the bus delimiter in the DSPF netlist.
- *Misc Options* - Specifies additional options for the DSPF netlist.

5. On the *Power Nets* tab, select the nets that you want to include in the analysis.

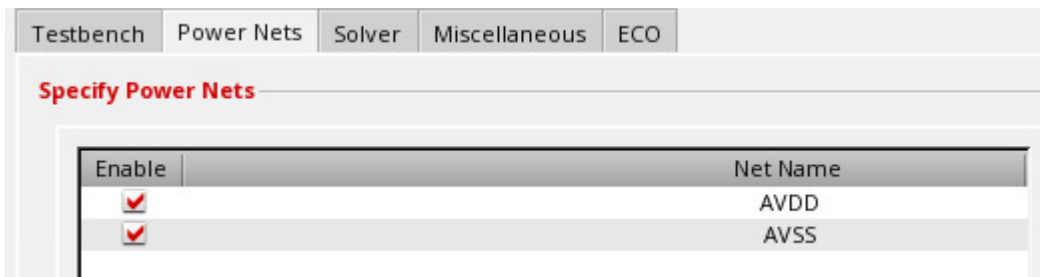

6. On the *Solver* tab, select an EM-IR preset option.

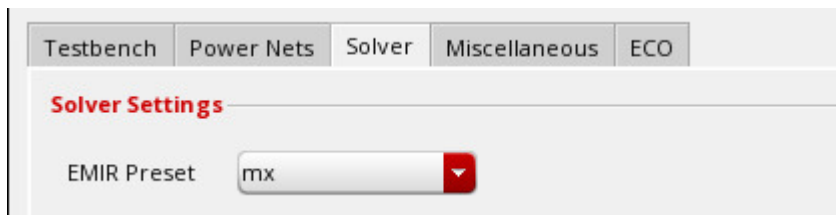

7. On the *Miscellaneous* tab, specify the additional options for the EM-IR run and the ECO file for what-if analysis. The *ECO File* option is supported only when the solver method is *2-Stage*.



Voltus-XFi Custom Power Integrity Solution User Guide

Setting Up and Running EM-IR Analysis

- On the *ECO* tab, select the net name, conversion type, tap/pin/node to be included and excluded, and the DSPF layer name. You can specify * to include all items to be converted. The *Include* field should not be empty.

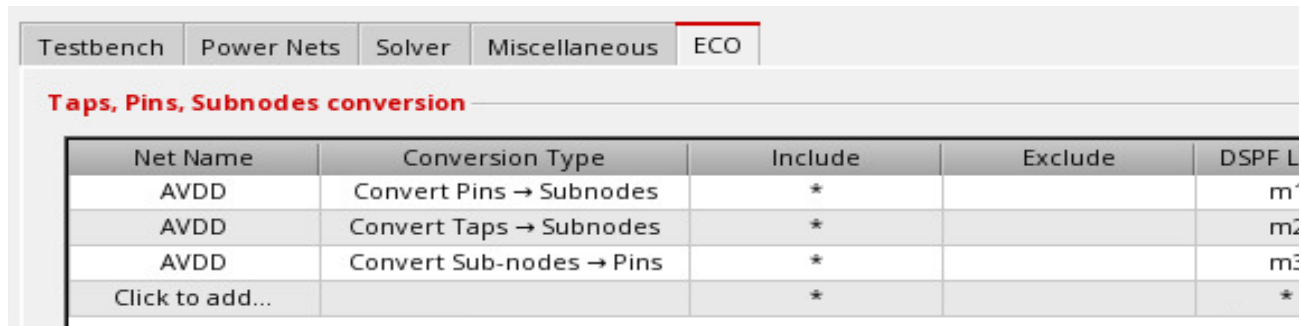

The following statements are included in the EMIR configuration file when the tap node, MPM3@44 :s of net AVDD is converted to a pin; the subnode VDD : 5 of net AVDD is converted to a tap node, and all pins of net AVDD are converted to subnodes:

```
spgs tap2pin net=[AVDD] include=[MPM3@44:s] layer[m1]
spgs sub2tap net=[AVDD] include=[VDD:5] layer[m2]
spgs pin2sub net=[AVDD] include=[*] layer[m3]
```

- Click *OK*.

The analysis details will be displayed in the *Analyses* tab. You can click *Add SPGS Analysis* again to add multiple analyses.

Related Topics

- [Voltus-XFi EM-IR GUI – Setup Tab](#)
- [Viewing EM-IR Analysis Results](#)
- [Performing Dynamic Analysis](#)
- [Performing Static Analysis](#)
- [EMIR Control File Options](#)

Performing Static Analysis

1. Choose *Setup – Analyses* from the task pane.
2. Select *Static Analysis* from the drop-down list, and click *Add Static Analysis*.

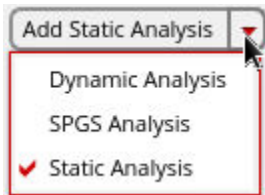

3. In the *Name* field, specify a name for the analysis setup.

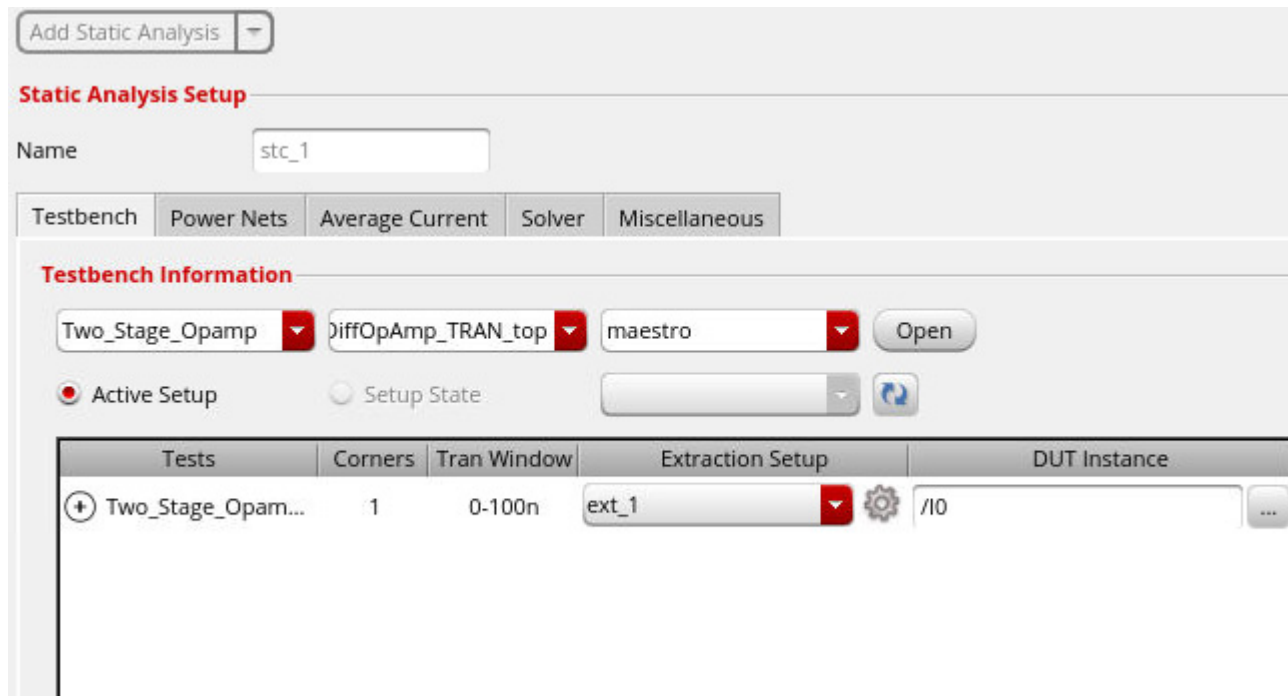

4. On the *Testbench* tab, import the testbench setup information from Virtuoso® ADE Explorer or Virtuoso® ADE Assembler.

To import the simulation setup from ADE:

- a. In the *Testbench Information* section, specify the maestro cellview from which to import a testbench setup.
- b. You can view the testbench setup in ADE by clicking *Open* next to the maestro cellview.

Voltus-XFi Custom Power Integrity Solution User Guide

Setting Up and Running EM-IR Analysis

- c. Click *Active Setup* or *Setup State* to select the testbench setup to use.

Note: The preferred use model is to create a Setup State for the EM-IR run for each block. This setup should contain the corners used for EM-IR analysis. Currently, corner groups are not supported.

- d. Click the + sign next to a test to view all the simulation corners defined for the test. You can map each simulation corner to a different extraction setup.

The *DUT instance* field will be automatically populated. If the *DUT Instance* name is not given, you can interactively select an instance from the schematic by clicking the browse button.

- e. You can click the *Advanced Settings* () icon in the *Extraction Setup* column to specify the following additional options for handling DSPF netlist.

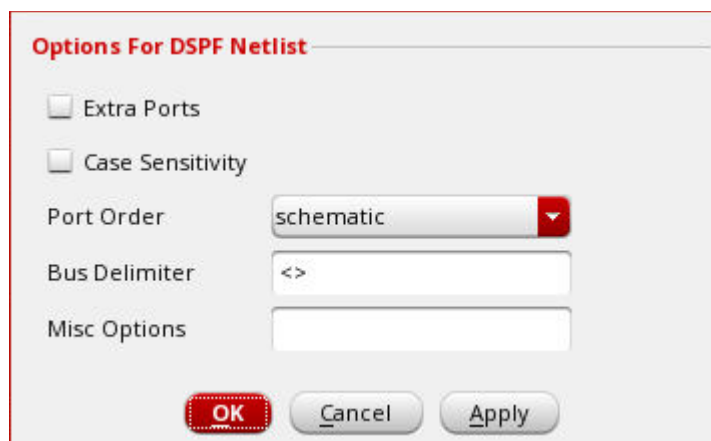

The dialog box titled "Options For DSPF Netlist" contains the following controls:

- Extra Ports
- Case Sensitivity
- Port Order: schematic (dropdown menu)
- Bus Delimiter: <> (text field)
- Misc Options: (empty text field)
- Buttons: OK, Cancel, Apply

- *Extra Ports* - If the port number in DSPF does not match the port number in the schematic netlist instance call, this option can be used to automatically handle extra ports. When selected, the extra ports in the DSPF subcircuit call are changed to internal nodes. In addition, the extra ports in the schematic subcircuit definition are connected to the nodes with the same name in the DSPF netlist.
- *Case Sensitivity* - Select this option to make the DSPF file case-sensitive.
- *Port Order* - Specifies whether the port order is taken from the schematic subcircuit definition or from the DSPF subcircuit definition.
- *Bus Delimiter* - Defines the bus delimiter in the DSPF netlist.
- *Misc Options* - Specifies additional options for the DSPF netlist.

Voltus-XFi Custom Power Integrity Solution User Guide

Setting Up and Running EM-IR Analysis

5. On the *Power Nets* tab, select the IR/EM analysis options and nets that you want to include in the analysis.

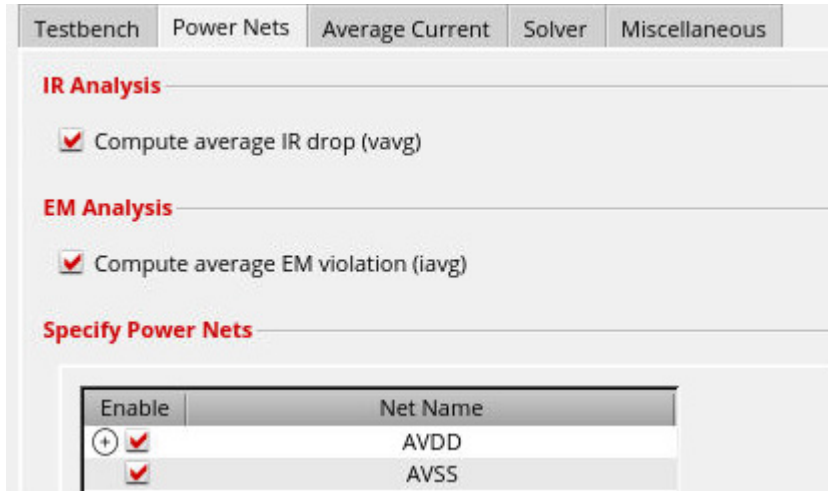

6. On the *Average Current* tab, browse and select the average current file for the specified power nets.

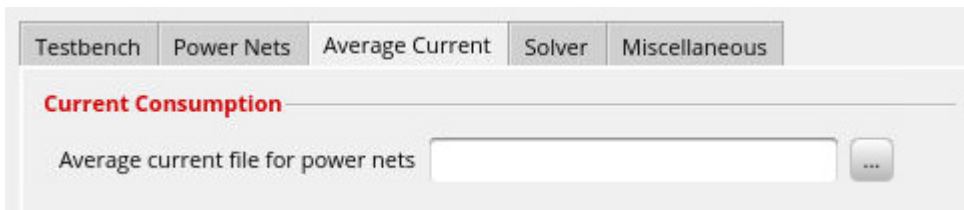

You can generate the current file from the dynamic analysis run. To generate the average current file, you need to include the option file in the *Miscellaneous* tab for *Dynamic Analysis Setup* in the *Setup - Analyses* tab. The options file should include the following command:

```
time window=[start_time stop_time] output=power  
filename=file_name.txt
```

Following is an example of the static-current file:

```
avdd 10m  
avss -10m
```

Voltus-XFi Custom Power Integrity Solution User Guide

Setting Up and Running EM-IR Analysis

7. On the *Solver* tab, select an EM-IR preset option.

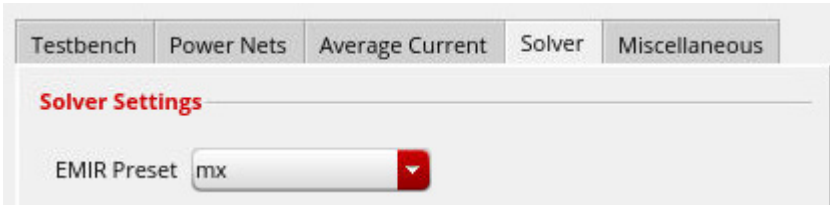

8. On the *Miscellaneous* tab, specify the additional options for the EM-IR run and the ECO file for what-if analysis.

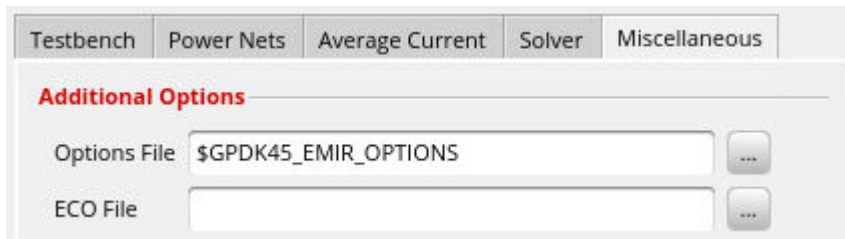

9. Click *OK*.

The analysis details will be displayed in the *Analyses* tab. You can click *Add Static Setup* again to add multiple analyses.

Related Topics

- [Voltus-XFi EM-IR GUI – Setup Tab](#)
- [Viewing EM-IR Analysis Results](#)
- [Performing Dynamic Analysis](#)
- [Performing Static Power Grid Solver Analysis](#)
- [EMIR Control File Options](#)

Running Post Layout Simulation

After specifying the parasitic extraction and EM-IR analysis setups, you can now generate a DSPF and run a simulation.

- [Generating a DSPF](#)
- [Running EM-IR Analysis](#)
- [Running DSPF Linter on a DSPF Netlist File](#)

Related Topics

- [Voltus-XFi EM-IR GUI – Run Tab](#)
- [Voltus-XFi EM-IR GUI – Diagnostic Tools Tab](#)
- [Voltus-XFi EM-IR Form Description](#)

Generating a DSPF

1. Click the *Run* tab from the task pane.
2. In the *Job Status* section, click the *Start Run* (▶) button next to the extraction run (*ext_1*).

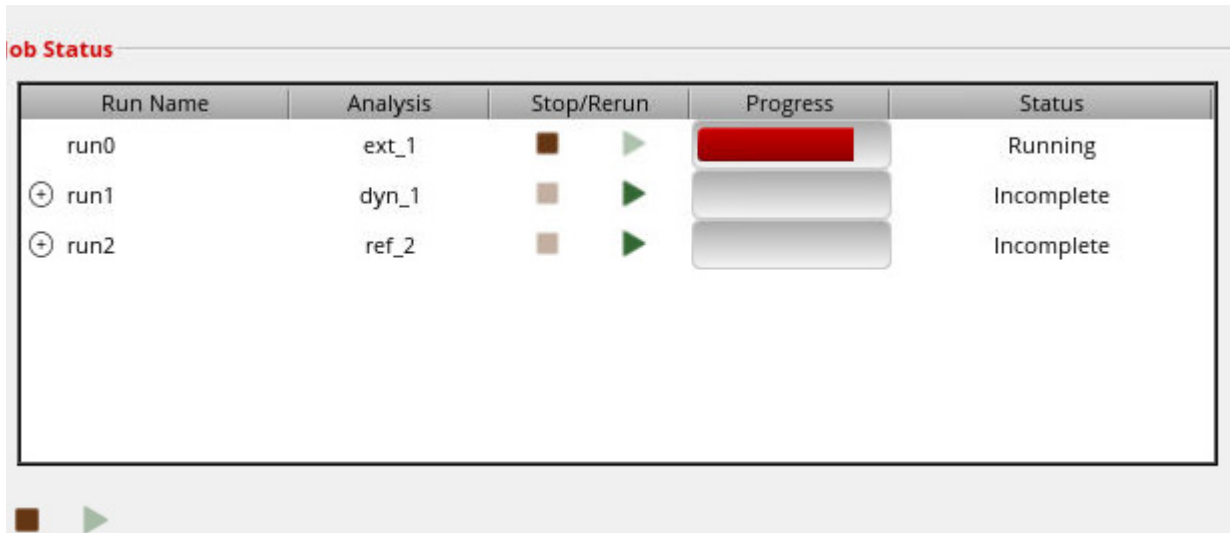

The extraction log appears at the lower section of the Voltus-XFi window. After the extraction run is complete, the log window displays the message “*Finished Extraction*”. The status changes from *Running* to *Complete*.

You can click the *Stop Run* (■) button to stop extraction.

3. You can check the log file for the extraction run from within the Voltus-XFi interface by right-clicking the extraction run name and selecting the *Open Log File* option.

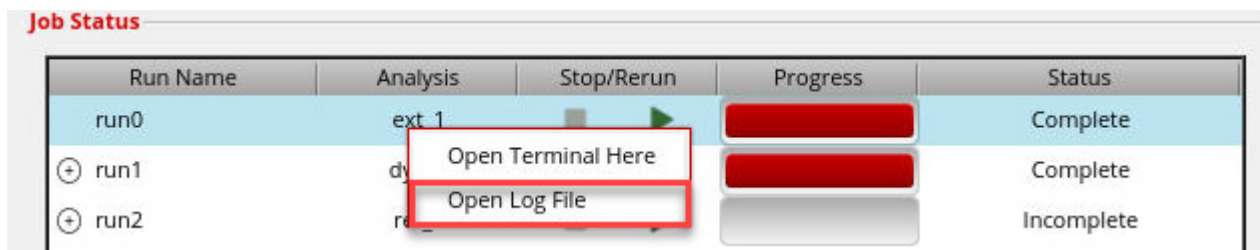

Voltus-XFi Custom Power Integrity Solution User Guide

Setting Up and Running EM-IR Analysis

4. You can open the Quantus output directory from within the Voltus-XFi interface by right-clicking the extraction run name and selecting the *Open Terminal Here* option.

The screenshot shows the 'Job Status' table in the Voltus-XFi interface. The table has five columns: Run Name, Analysis, Stop/Rerun, Progress, and Status. The rows are: run0 (ext_1, Complete), run1 (dyn_1, Complete), and run2 (ref_2, Incomplete). A red box highlights the 'Open Terminal Here' and 'Open Log File' options in the context menu for run1. A red arrow points from this menu to the 'Log Viewer' window below. The Log Viewer window shows a terminal session with the command 'ls' and the output 'DiffOpAmp.dspf.gz', which is highlighted with a red box.

Run Name	Analysis	Stop/Rerun	Progress	Status
run0	ext_1			Complete
run1	dyn_1			Complete
run2	ref_2			Incomplete

```
Log Viewer
dyn_1 Two_Stage_Opamp_DiffOpAmp_TRAN_top_1 EMIR
sjfhw748:/it/sjclapa06p6_scratch01/.../pire_2022_07_30/tungstenisr26/Voltus_XFi_RAK_IC
l> ls
DiffOpAmp.dspf.gz      DiffOpAmp.dspf.gz.log  DiffOpAmp.dspf.gz.pin_info  DiffOp
```

Related Topics

- [Voltus-XFi EM-IR GUI – Run Tab](#)
- [Voltus-XFi EM-IR Form Description](#)
- [Running EM-IR Analysis](#)
- [Running DSPF Linter on a DSPF Netlist File](#)

Running EM-IR Analysis

1. Click the *Run* tab from the task pane.
2. In the *Job Status* section, click the *Start Run* (▶) button next to the analysis run (*dyn_1*).

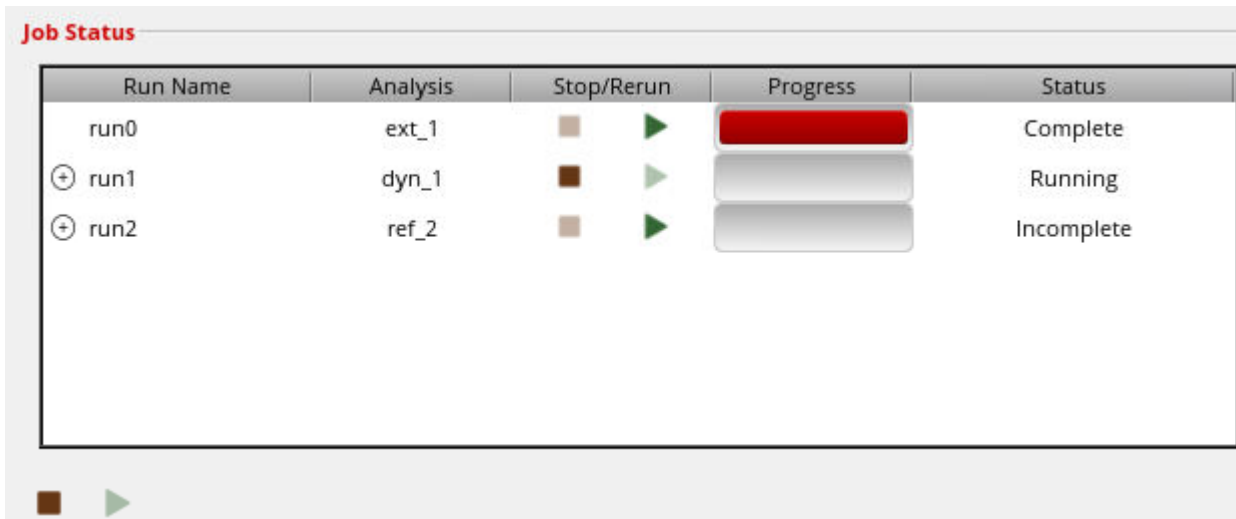

The simulation name (*run1* in this image) has a tree view structure that can be expanded to view the corner names.

After the analysis run is complete, the status changes from *Running* to *Complete*. After the simulation finishes, VIVA may open. To prevent VIVA from opening, open ADE Explorer, select *Results > Printing/Plotting Options*, and set *Plotting Option* to *None*.

Note: You can also click “*Start All Runs* (▶)” to sequentially run parasitic extraction and post-layout simulation in a single step. You cannot add or edit the analysis and extraction setups while running all tasks.

3. You can check the log file for the simulation run from within the Voltus-XFi interface by right-clicking the analysis run name and selecting the *Open Log File* option.



Voltus-XFi Custom Power Integrity Solution User Guide

Setting Up and Running EM-IR Analysis

4. You can open the simulation output directory from within the Voltus-XFi interface by right-clicking the analysis run name and selecting the *Open Terminal Here* option.

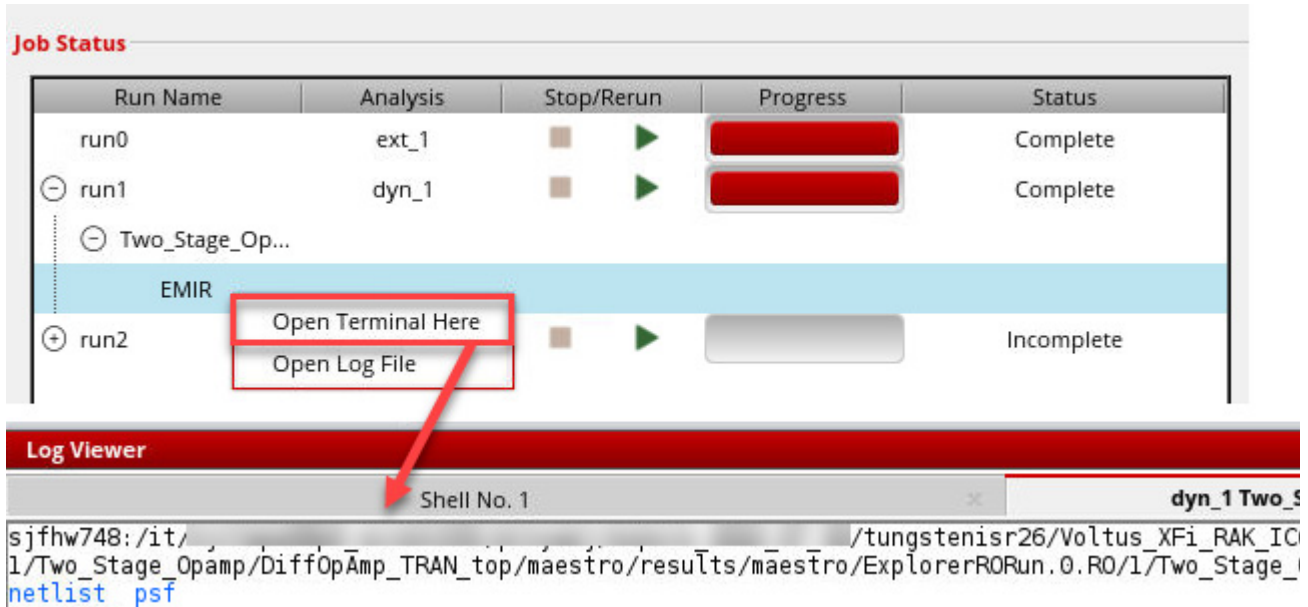

The '*netlist*' directory contains all the input files that are required by the simulator. The '*psf*' directory contains all the output results from the simulator.

The *psf* directory includes the following files:

- ❑ Voltus-XFi log file (`input.emirtap.vfilog`)
- ❑ Time window file (`input.emirtap.bin_time_window`)
- ❑ EM-IR configuration file (`input.emirtap.conf`)
- ❑ Result database (`input.emirtap.emir0.wdb`)
- ❑ Simulation result database (`input.emirtap.emir0_bin`)
- ❑ Electromigration analysis results (`input.emirtap.rpt_em`)
- ❑ Voltage drop results (`input.emirtap.rpt_ir`)
- ❑ Pin current results (`input.emirtap.rpt_pin`)
- ❑ Power gate report (`input.emirtap.rpt_pwg`)

Related Topics

- [Viewing EM-IR Analysis Results](#)

Voltus-XFi Custom Power Integrity Solution User Guide

Setting Up and Running EM-IR Analysis

- [Voltus-XFi EM-IR GUI – Run Tab](#)
- [Voltus-XFi EM-IR Form Description](#)

Running DSPF Linter on a DSPF Netlist File

The DSPF Linter utility analyzes a DSPF file, reports problems that may cause simulation problems, and creates an EM-IR conf file with recommended mapping statements.

To run DSPF Linter, do the following:

1. Choose *Diagnostic Tools – DSPF Linter* from the task pane.
2. Click the *DSPF File* column, browse to and select the DSPF file that you want to use, and press the *Enter* key.
3. Click the *Start DSPF Checker* () button.

When the run is complete, the *Status* column shows *Completed*.

This utility creates the following files that are displayed in the *DSPF Linter Results* section:

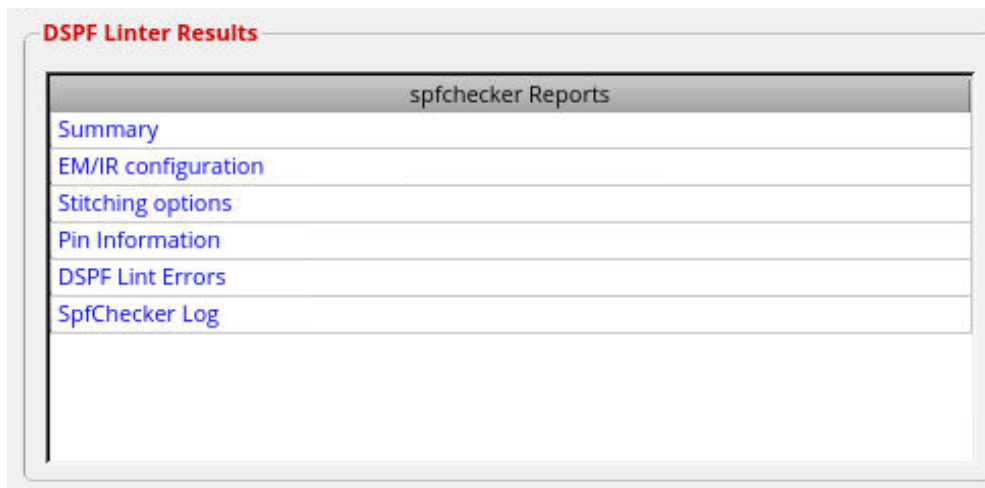

- *Summary* - Gives a summary of the DSPF netlist file.
- *EM/IR Configuration* - Specifies the recommended settings for the EM-IR config file.
- *Stitching Options* - Specifies the recommended (SPICE format) settings for DSPF back annotation.
- *Pin Information* - Gives the x and y coordinates and the layer name of each pin.
- *DSPF Lint Errors* - Displays DSPF related errors and islands that need to be fixed for current accuracy.
- *SpfChecker Log* - Detailed SPF checker log file.

Voltus-XFi Custom Power Integrity Solution User Guide

Setting Up and Running EM-IR Analysis

Related Topics

- [Viewing EM-IR Analysis Results](#)
- [Voltus-XFi EM-IR GUI – Run Tab](#)
- [Voltus-XFi EM-IR Form Description](#)

Voltus-XFi Custom Power Integrity Solution User Guide
Setting Up and Running EM-IR Analysis

Viewing EM-IR Analysis Results

There are two ways of launching Voltus-XFi Results Browser to view EM-IR analysis results:

- from the Voltus-XFi window
- from Virtuoso Layout

To view the EM-IR analysis results using the Voltus-XFi window, do the following:

1. On the Voltus-XFi window, choose *Results* from the task pane.
2. Select an analysis, the test, and the corner for which you want to view the results.

The *Net Summary* tab gives a summary of the IR and EM results for each net. This tab allows you to view the violations in the *Results* page before loading the Results Browser assistant. This tab displays only those IR/EM columns for which the analysis is done. For example, the column name *Max IR avg* will be shown only if the average IR drop analysis was enabled in the simulation run. To display or hide a column, right-click on the column header and select the column name.

Voltus-XFi Custom Power Integrity Solution User Guide

Viewing EM-IR Analysis Results

The nets with EM violations/high IR drop values are displayed in red font.

Project Directory: `1_voltusxfi_isr34/Voltus_XFi_RAK_IC618ISR32/XFiResults_Spectre_ISR19/zambezi45_sim/pl`

Analysis Test Corn

- dyn_1
- Interactive.0.RO
- zambezi45_sim_pll_reg_sim_1
- C0
- Interactive.2.RO
- Interactive.3.RO
- EMIR_Setup.0.RO
- ref_2

Net Summary Plots Reports

433 nets (dyn_1 → Interactive.0.RO → zambezi45_sim_pll_reg_sim_1 → C0)

Net Name	EM Violation Count	Max IR peak(mV)	Max J/Jmax	R Count	
en_fh			0.178851	168	38.05f
avddlf	12	8.10999	2.20366	3086	53.48f
avddhf	937		58.3818	5955	227.5f

The following color codes for corner names indicate the status of the simulation run:

- ❑ a red-highlighted corner name indicates that the run has failed. The tooltip displays the status as “*simulation failed*”, timestamp, and the path to the history directory.
- ❑ a yellow-highlighted corner name indicates that the simulation run is complete but the EM-IR results are not generated. The tooltip displays the status as “*EMIR Results database is not found*”, timestamp, and the path to the history directory.
- ❑ a green-highlighted corner name indicates that the simulation run has passed. The tooltip displays the status as “*simulation passed*”, timestamp, and the path to the history directory.

The following is an example of a yellow-highlighted corner name:

Voltus-XFi Custom Power Integrity Solution User Guide

Viewing EM-IR Analysis Results

C1	
Status	EMIR Results database not found
Time	Oct 3 07:39:16 2023
Directory	.../Interactive.53.RO/1/ TRAN_EMIR_iter

3. Select the *Plots* tab to view the violations in the layout.

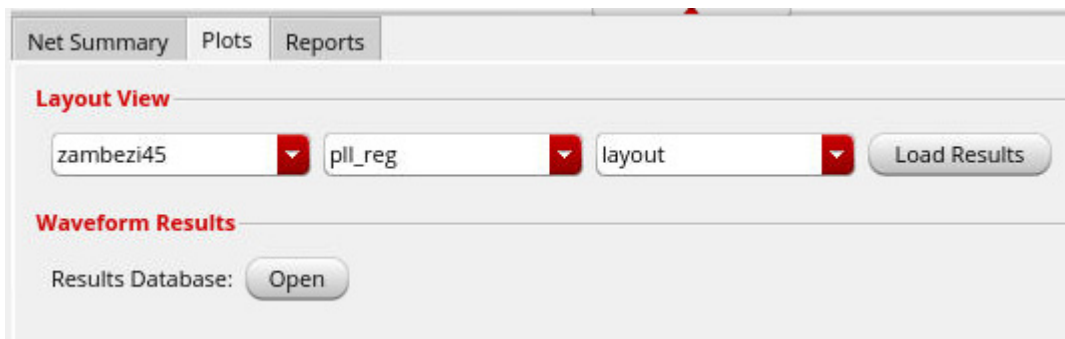

4. In the *Layout View* section, select the layout, cell, and view from the respective drop-down lists.
5. Click *Load Results*.

The Virtuoso Layout window opens in another tab, with the high-level design summary displayed in Results Browser.

Note: You can right-click a corner name to access a shortcut menu of some of the common tasks that can be performed, such as open a terminal from within the Voltus-XFi interface, load analysis results on Virtuoso layout, and view the current and voltage waveforms in VIVA waveform viewer. The *Load Results in Layout* option in the shortcut menu will be grayed out if the corner name is yellow-highlighted indicating that result

Voltus-XFi Custom Power Integrity Solution User Guide

Viewing EM-IR Analysis Results

loading is disabled because the EM-IR results database is not found.

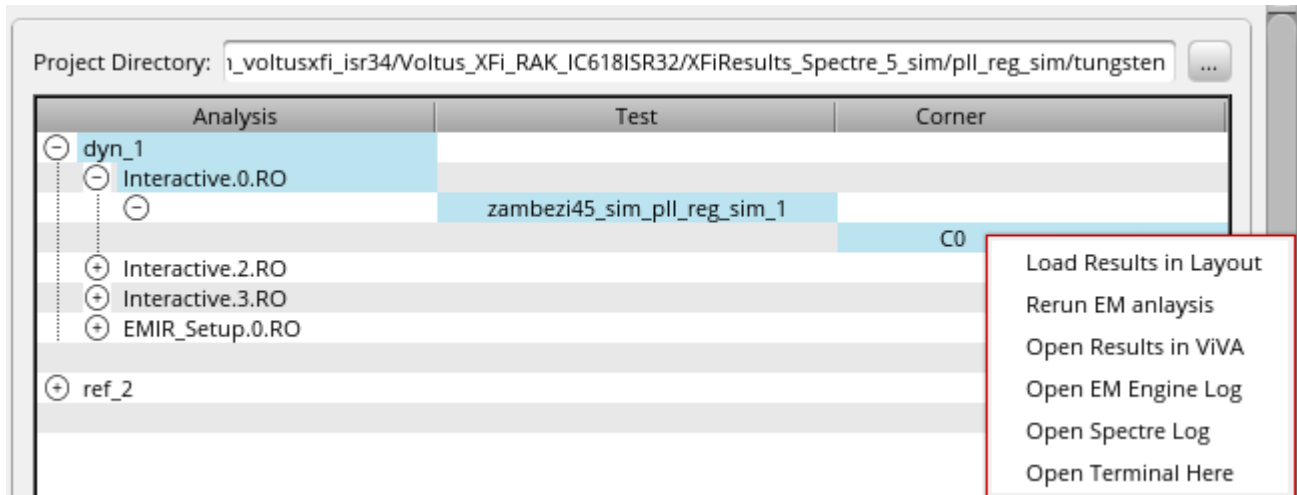

To view the EM-IR analysis results using Virtuoso Layout, do the following:

1. On the Virtuoso Layout window, choose *Window – Assistants – Voltus-XFi Results Browser*.

Voltus-XFi Custom Power Integrity Solution User Guide

Viewing EM-IR Analysis Results

The Voltus-XFi Results Browser assistant is added as a docked assistant pane within the current layout window.

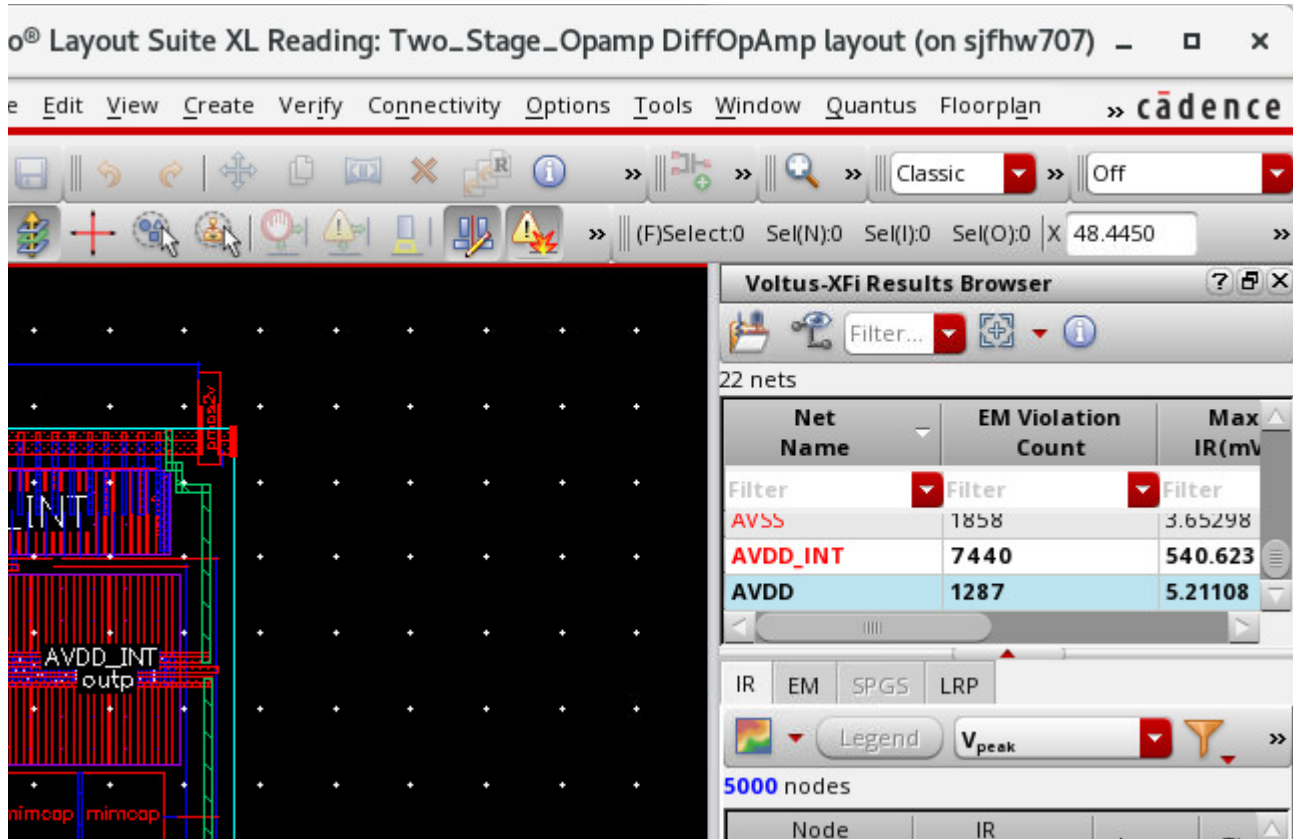

2. Click the *Load EMIR results* () icon and load the EM-IR results database.

Related Topics

- [The Voltus-XFi Results Browser Graphical User Interface](#)
- [Visualizing EM-IR Analysis Results using Voltus-XFi Results Browser](#)
- [Viewing EM-IR Analysis Reports](#)
- [Viewing Waveform Results](#)

Working with History Items

The *Results* tab in the Voltus-XFi GUI allows you to preserve the history of simulation results. Using this feature, you can view and load multiple simulation results corresponding to the saved history items. The file naming convention for history items is according to the maestro history name, that is, the default is *Interactive* for the active setup of the view and user-specified name for the setup state of the view. In the following image, *Interactive.0.RO*, *Interactive.1.RO*, *Interactive.2.RO*, and *Interactive.3.RO* are names of the history items for the active setup of the view, and *EMIR_Setup.0.RO* is the name of the history item for the setup state of the view.

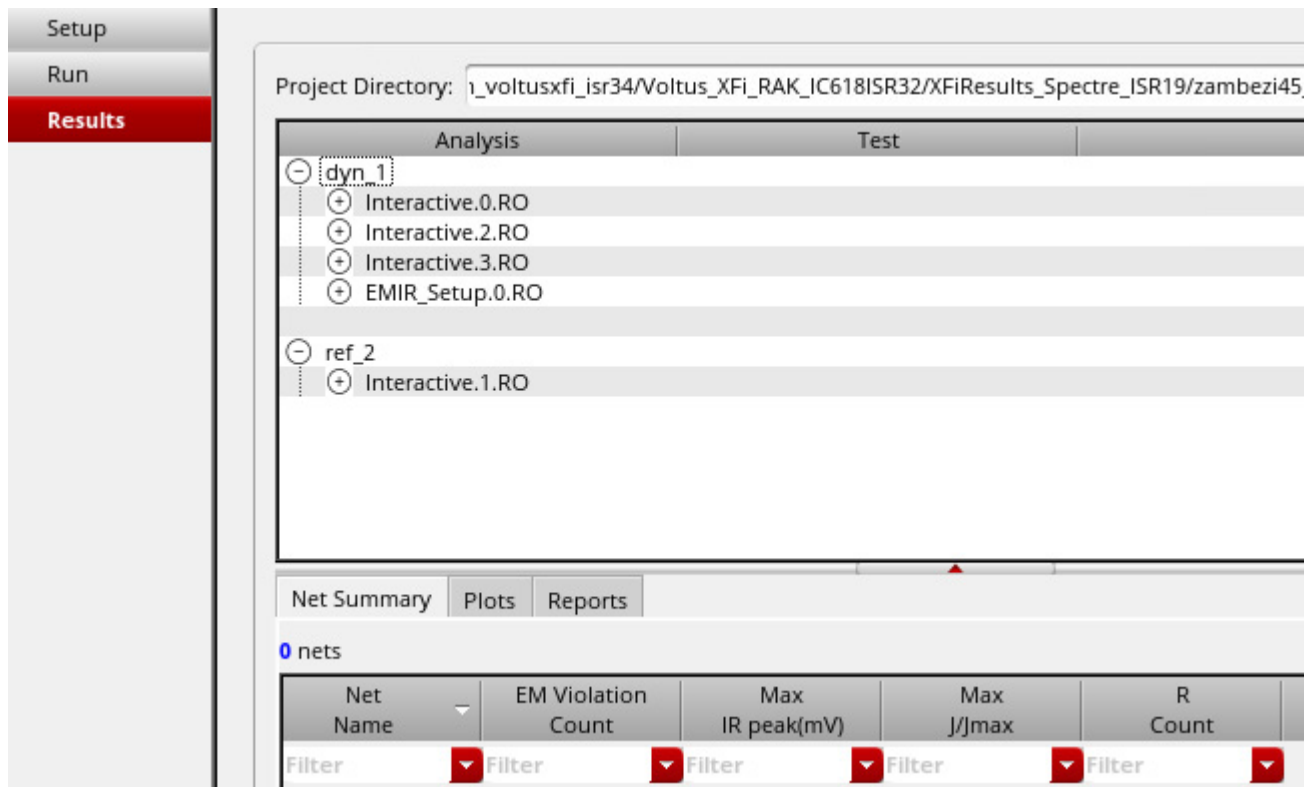

To load the simulation result corresponding to a specific history item, do the following:

1. On the Voltus-XFi window, choose *Results* from the task pane.

Voltus-XFi Custom Power Integrity Solution User Guide

Viewing EM-IR Analysis Results

- Expand the analysis tree by clicking the plus sign (+) to the left of the analysis you want to load.

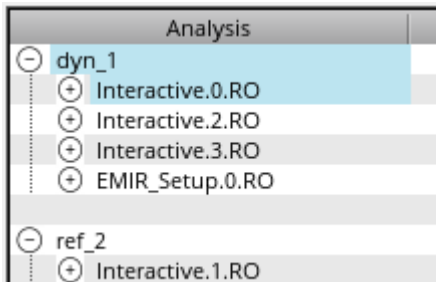

- Click the plus sign (+) to the left of the required history item and test.

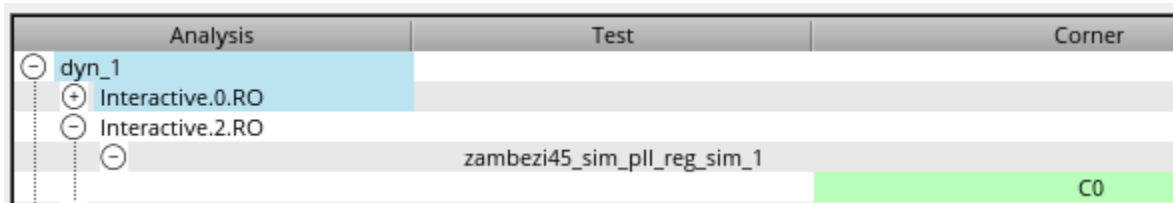

Hover your mouse pointer over the name of an analysis to view the analysis type, over the history item to view its timestamp, and over the corner name to view its status (simulation passed/failed), timestamp, and the path to the history directory.

- Right-click the corner name and select *Load Results in Layout* from the shortcut menu.

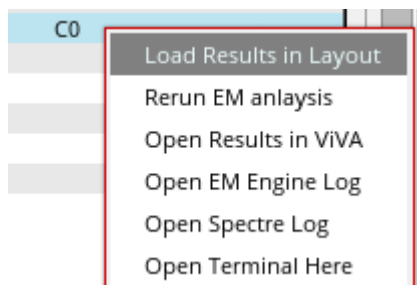

The Virtuoso Layout window opens in another tab, with the high-level design summary displayed in Results Browser.

Related Topics

- [Visualizing EM-IR Analysis Results using Voltus-XFi Results Browser](#)
- [Viewing EM-IR Analysis Reports](#)

Voltus-XFi Custom Power Integrity Solution User Guide

Viewing EM-IR Analysis Results

- Viewing Waveform Results

Rerunning EM Analysis with Different EM Settings

To rerun the EM analysis with modified EM settings, do the following:

1. On the Voltus-XFi window, choose *Results* from the task pane.
2. Right-click a history item, test, or corner for which you want to rerun EM analysis.
3. Select the *Rerun EM analysis* option.

Depending on your selection, the shortcut option allows you to run EM analysis for all tests and corners of an analysis, all corners of a test, or a specific corner.

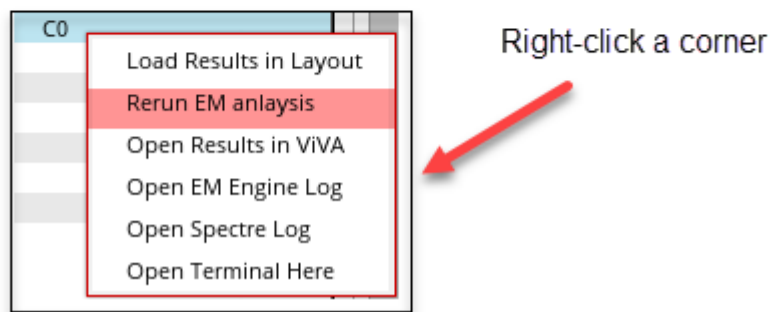
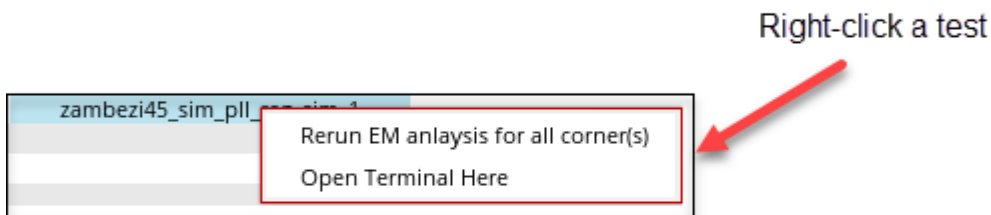
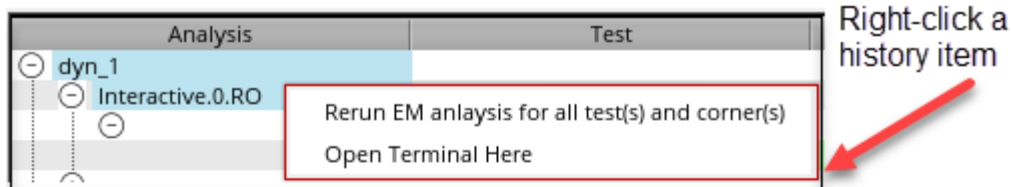

An EMIR results database file (.wdb) is generated with the new EM settings that can be loaded in the Voltus-XFi Result Browser. The .wdb file is saved in the rerun (for example, 00_rereun_em, 01_rereun_em, and so on) folder in the psf directory.

Related Topics

- [Visualizing EM-IR Analysis Results using Voltus-XFi Results Browser](#)

The Voltus-XFi Results Browser Graphical User Interface

The Voltus-XFi Results Browser lets you visualize and debug the EM IR results generated for a design.

The following section explains the Voltus-XFi Results Browser interface:

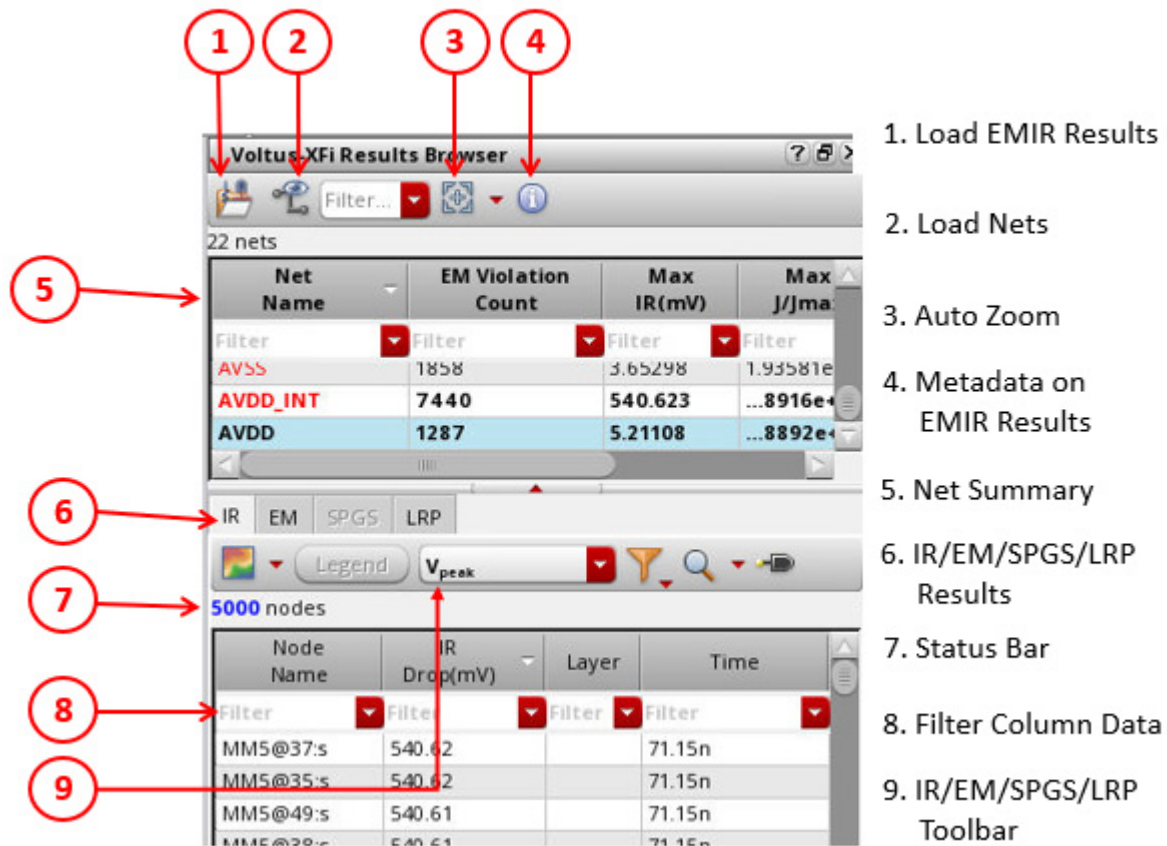

- 1. Load EMIR Results Database** - Allows you to browse and select the EM-IR database to be loaded from the output directory.
- 2. Load Nets** - Allows you to load and view the nodes/resistors/paths for the selected net. Select a net from the Net Summary table and click *Load Nets*. You can load multiple nets by using *Shift-Click* or *Ctrl-Click*.
- 3. Auto Zoom** - Controls whether the Auto Zoom function of the Voltus-XFi Results Browser is set to *Fixed* mode or *Minimal* mode. The slider defines a ratio specifying how much of the available canvas area is occupied by the merged bounding box of the selected markers after the zoom is performed. For example, if you set it to 4, the ratio is 1/4; if you set it to 10, the ratio is 1/10, and so on.

Voltus-XFi Custom Power Integrity Solution User Guide

Viewing EM-IR Analysis Results

- ❑ *Fixed* - Applies the ratio to the bounding box of all the selected markers. So, if set to 4, the merged bounding box of all the selected markers occupies 1/4 of the canvas area after the Auto Zoom is performed.
- ❑ *Minimal* - Defines a minimum zoom level that will ensure all the selected nodes are visible in the canvas. For example, assume the scale is set to 4. If the merged bounding box of the selected markers is greater than the canvas size, the display zooms out so that the bounding box fits in the canvas.

4. Metadata on EM-IR Results Database - Opens the following form that gives the metadata information about the EM-IR database, such as result type, simulation temperature, and hierarchy.

EMIR DB:
...RO/2/Two_Stage_Opamp_DiffOpAmp_TRAN_top_1/psf/
input.emirtap.emir0.wdb

Metric	Value
DB Creation Time	2021-Sep-22 04:23:49
Voltus-XFi version	v06.88-s075_1
Result type	tran
Transient Start	0
Transient Stop	3e-8

5. Net Summary - Gives a summary of all the nets in the design for which the EM-IR analysis is done. The nets with EM violations/high IR drop values are displayed in red font. This section includes columns for the net name, maximum IR drop value, EM violation count, number of parasitic resistors, and total capacitance for each net. Each of the columns can be sorted in ascending or descending order. You can view the details of the selected net in the *IR*, *EM*, *SPGS*, and *LRP* tabs.

The *Net Summary* section displays only those IR/EM columns for which the analysis is done. For example, column name *Max IR avg* will be shown only if the average IR drop

Voltus-XFi Custom Power Integrity Solution User Guide

Viewing EM-IR Analysis Results

analysis was enabled in the simulation run. To display/hide a column, right-click on the column header and select the column name.

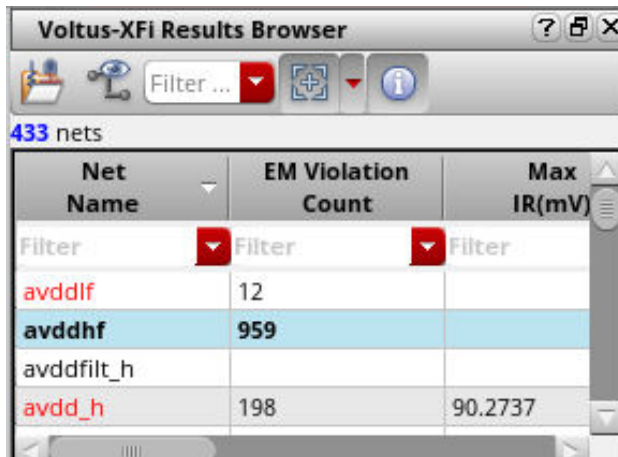

The screenshot shows the 'Voltus-XFi Results Browser' window. At the top, it indicates '433 nets'. Below this is a table with three columns: 'Net Name', 'EM Violation Count', and 'Max IR(mV)'. The table contains several rows, with 'avddhf' highlighted in blue, indicating it has the highest violation count of 959. Other rows include 'avddf' (12), 'avddfilt_h', and 'avdd_h' (198, 90.2737).

Net Name	EM Violation Count	Max IR(mV)
Filter	Filter	Filter
avddf	12	
avddhf	959	
avddfilt_h		
avdd_h	198	90.2737

6. IR Drop/EM/SPGS/LRP Results - The results section has 4 tabs:

- IR** - Gives the detailed IR drop information about the net selected in the Net Summary section. This section displays only the first 5000 rows, listing the nodes with top 5000 IR values. When multiple nets are selected, this section displays the top 5000 rows across all selected nets. The section includes the node name, IR drop value, layer on which the node is located, location (x, y coordinates of the node), and time for IR drop. This tab is visible for static and dynamic analyses.
- EM** - Gives detailed electromigration information about the net selected in the Net Summary section. This section displays only the first 5000 rows, listing the resistors with top 5000 J/Jmax violations. The section includes the resistor name, current density limit, resistance value, layer on which the resistor is located, location (x1, y1, x2, y2 coordinates of the resistor), width of the resistor, length of the resistor, max DC current, path length, number of via cuts, and via cut area. This tab is visible for static and dynamic analyses.
- SPGS** - Displays the resistance between the global pin and all taps ordered highest to lowest. The resistances calculated by SPGS are electrically equivalent resistances, and not the summation of resistors. The section includes column names, such as the R effective value, node name, layer on which the node is located, and DSPF layer name. This tab is visible only for SPGS analysis.
- LRP** - Displays the LRP for a net. This tab is enabled only when you load a single net, not applicable for loading multiple nets. Click *Compute LRP*  to calculate the LRP for all nodes of the net. When you select a node in the LRP table, the violation marker is highlighted in the layout. This tab is visible for static and dynamic analyses.

Voltus-XFi Custom Power Integrity Solution User Guide

Viewing EM-IR Analysis Results

An example is shown below.

The screenshot displays the Voltus-XFi Results Browser interface. The left pane shows a PCB layout with a white line indicating LRP for the nodes on the selected net. The right pane shows the following data:

Net Name	EM Violation Count	Max IR(mV)
avddf	12	
avddhf	959	
avddfilt_h		

Starting Node	Resistance (Ω)
avddhf:999	12.7126
avddhf:998	12.4146
avddhf:997	12.1166
avddhf:996	11.8187

Resistance (Ω)	Voltage Drop (mV)	Length (μm)
0.063	0.000	0.000

The white line indicates LRP for the nodes on the selected net.

- Status Bar** - Status Bar displays useful information such as number of rows in the *IR* /*EM*/*SPGS*/*LRP* sections, confirmation message to load powergated group of nets together, queried region information, and loading nets status. The number of nets in a design are displayed in the Net Summary section, the number of nodes is displayed in the *IR* and *SPGS* tabs, the number of resistors is displayed in the *EM* tab, and the number of paths is displayed in the *LRP* tab.
- Filter Column Data** - The *Filter* field on top of each column heading allows you to filter column values based on the string you enter. Example: If you have 695 rows appearing

Voltus-XFi Custom Power Integrity Solution User Guide

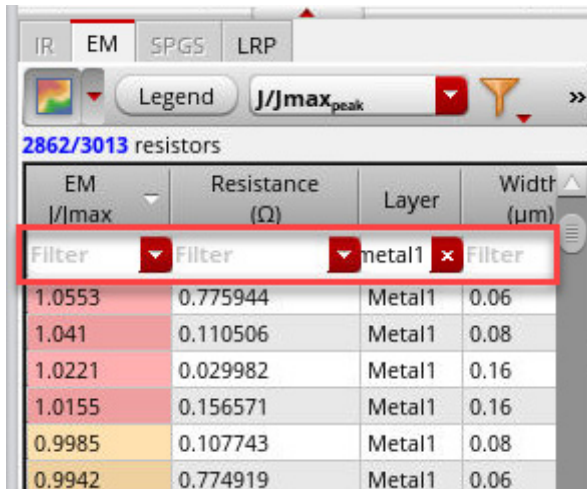

Viewing EM-IR Analysis Results

in the *EM* tab and you want to filter out the layer *metal1*, enter *metal1* in the *Layer* field. The *EM* tab displays only those rows with layers starting with *metal1*.





Note: Hide columns in a table so that you can focus on a few columns. Otherwise, you may have to scroll horizontally to access an out-of-view column. To hide a column in the Net Summary or *IR/EM/SPGS/LRP* table, right-click a column header and select *Hide Column*. To display a column that is hidden, right-click any column header and select the column name. You can select *Show All Columns* from the right-click menu to view all columns.

9. IR/EM/SPGS/LRP Analysis Toolbar - The analysis toolbar contains the following icons:

Icon	Icon Name	Function
	<i>Plot Results</i>	Controls the display of the selected plot type for the net selected in the Net Summary table. You can also control the transparency of the plot by using the Min-Max slider, accessed by clicking the drop-down button.
	<i>Legend (Plot Color)</i>	Displays the violation range for the EM-IR results. A continuous RGB gradient is used to highlight the worst violation regions in the design. The vast range of color options provided by the RGB gradient makes it easier to view a range of violations in the layout.





Voltus-XFi Custom Power Integrity Solution User Guide

Viewing EM-IR Analysis Results

Icon	Icon Name	Function
	<p><i>Select Plot Type</i></p>	<p>Displays the list of plots supported.</p> <p>When the <i>IR</i> tab is selected, the following types of IR drop analysis results plots are available:</p> <ul style="list-style-type: none"> ■ <i>Peak IR Drop (V_{peak})</i> ■ <i>Average IR Drop (V_{peak})</i> ■ <i>Transistor Peak IR Drop ($V_{tappeak}$)</i> ■ <i>Transistor Average Current (I_{tapavg})</i> ■ <i>Transistor RMS Current (I_{taprms})</i> ■ <i>Transistor Peak Current ($I_{tappeak}$)</i> <p>When the <i>EM</i> tab is selected, the following types of EM analysis results plots are available:</p> <ul style="list-style-type: none"> ■ <i>Peak J/JMAX ($J/JMAX_{peak}$)</i> ■ <i>Average J/JMAX ($J/JMAX_{avg}$)</i> ■ <i>Absolute Average J/JMAX ($J/JMAX_{absavg}$)</i> ■ <i>ACPeak J/JMAX ($J/JMAX_{acpeak}$)</i> ■ <i>Peak Current (I_{peak})</i> ■ <i>Average Current (I_{avg})</i> ■ <i>RMS Current (I_{rms})</i>
	<p><i>Filter Layer from Results</i></p>	<p>Controls the layers to be displayed in the layout. You can click the drop-down button to select specific layers, show/hide all layers, show only via layers, and show all device layers.</p> <p>When the <i>Show Device Layers</i> option is selected from the drop-down button, the device layers from the self-heating effect (SHE) analysis parameter file will be displayed along with the DSPF layers. The <i>Show Device Layers</i> option is applicable only to the EM SHE plots.</p>



Voltus-XFi Custom Power Integrity Solution User Guide

Viewing EM-IR Analysis Results

Icon	Icon Name	Function
	<i>Query Region</i>	Allows to query the EM-IR results for the selected net. You can click the drop-down button to query results for either an area or a shape, and then make the selection in the layout. Depending upon whether the query is for IR drop or EM analysis, the corresponding results (nodes/resistors) are displayed in the <i>IR</i> or <i>EM</i> tab.
	<i>Voltage Source</i>	Highlights the voltage source on the layout.
	<i>Thermal Plots</i>	Enables or disables the display of thermal data and plots. This option is specific to the <i>EM</i> tab.
LRP Options		
	<i>Compute LRP</i>	Computes LRP values for all nodes of the selected net. This information is populated in the LRP table.
	<i>Shorted Layers</i>	Specifies to short specific layers for LRP analysis. For details, see Performing LRP Analysis .

Voltus-XFi Custom Power Integrity Solution User Guide

Viewing EM-IR Analysis Results

Icon	Icon Name	Function																																								
	<i>Merge Resistors on Same Segment</i>	<p>Allows to view the combined resistance values for a layer in the resistance path table. When this option is clicked, all the resistors on a layer, metal or via, will be merged into one segment for the purpose of LRP reporting. In the image below, the resistors on layer Metal 7 are shown in the resistor path table.</p> <table border="1" data-bbox="716 636 1453 926"> <thead> <tr> <th>Resistance (Ω)</th> <th>Voltage Drop (mV)</th> <th>Layer</th> <th>Leng (μm)</th> </tr> </thead> <tbody> <tr> <td>Filter</td> <td>Filter</td> <td>metal7</td> <td>Filter</td> </tr> <tr> <td>0.125</td> <td>0.062</td> <td>Metal7</td> <td>13.385</td> </tr> <tr> <td>0.003</td> <td>0.002</td> <td>Metal7</td> <td>0.235</td> </tr> <tr> <td>0.003</td> <td>0.002</td> <td>Metal7</td> <td>0.235</td> </tr> <tr> <td>1.169</td> <td>0.585</td> <td>Metal7</td> <td>125.435</td> </tr> <tr> <td>0.003</td> <td>0.001</td> <td>Metal7</td> <td>0.320</td> </tr> </tbody> </table> <p>In the following image, the resistors for the layer Metal 7 are combined to display the resistor path for the segment.</p> <table border="1" data-bbox="716 1150 1453 1318"> <thead> <tr> <th>Resistance (Ω)</th> <th>Voltage Drop (mV)</th> <th>Layer</th> <th>Leng (μm)</th> </tr> </thead> <tbody> <tr> <td>Filter</td> <td>Filter</td> <td>metal7</td> <td>Filter</td> </tr> <tr> <td>1.644</td> <td>0.685</td> <td>Metal7</td> <td>171.355</td> </tr> </tbody> </table>	Resistance (Ω)	Voltage Drop (mV)	Layer	Leng (μm)	Filter	Filter	metal7	Filter	0.125	0.062	Metal7	13.385	0.003	0.002	Metal7	0.235	0.003	0.002	Metal7	0.235	1.169	0.585	Metal7	125.435	0.003	0.001	Metal7	0.320	Resistance (Ω)	Voltage Drop (mV)	Layer	Leng (μm)	Filter	Filter	metal7	Filter	1.644	0.685	Metal7	171.355
Resistance (Ω)	Voltage Drop (mV)	Layer	Leng (μm)																																							
Filter	Filter	metal7	Filter																																							
0.125	0.062	Metal7	13.385																																							
0.003	0.002	Metal7	0.235																																							
0.003	0.002	Metal7	0.235																																							
1.169	0.585	Metal7	125.435																																							
0.003	0.001	Metal7	0.320																																							
Resistance (Ω)	Voltage Drop (mV)	Layer	Leng (μm)																																							
Filter	Filter	metal7	Filter																																							
1.644	0.685	Metal7	171.355																																							
	<i>Print Report</i>	Generates LRP report for the selected node. Click <i>Print Report</i> to specify the name of the report file and then click <i>Save</i> . The report opens in the console.																																								

Related Topics

- [Visualizing EM-IR Analysis Results using Voltus-XFi Results Browser](#)
- [Displaying and Hiding Voltus-XFi Results Browser](#)
- [Performing LRP Analysis](#)

Customizing Data Loading of EM-IR Analysis Results

The Voltus-XFi Results Browser assistant allows you to perform the following to improve efficiency and speed when loading the analysis results:

- enable caching of net data, that is, keep the nets once loaded in memory to speed up subsequent reload in the same session
- select the layers to be loaded
- customize and save the result loading settings for the EM, IR, and SPGS analyses

To customize the loading of results:

1. On the *Voltus-XFi Results Browser*, click *Load EMIR Results* () to load the results database.

The DB Load Options browse form appears.

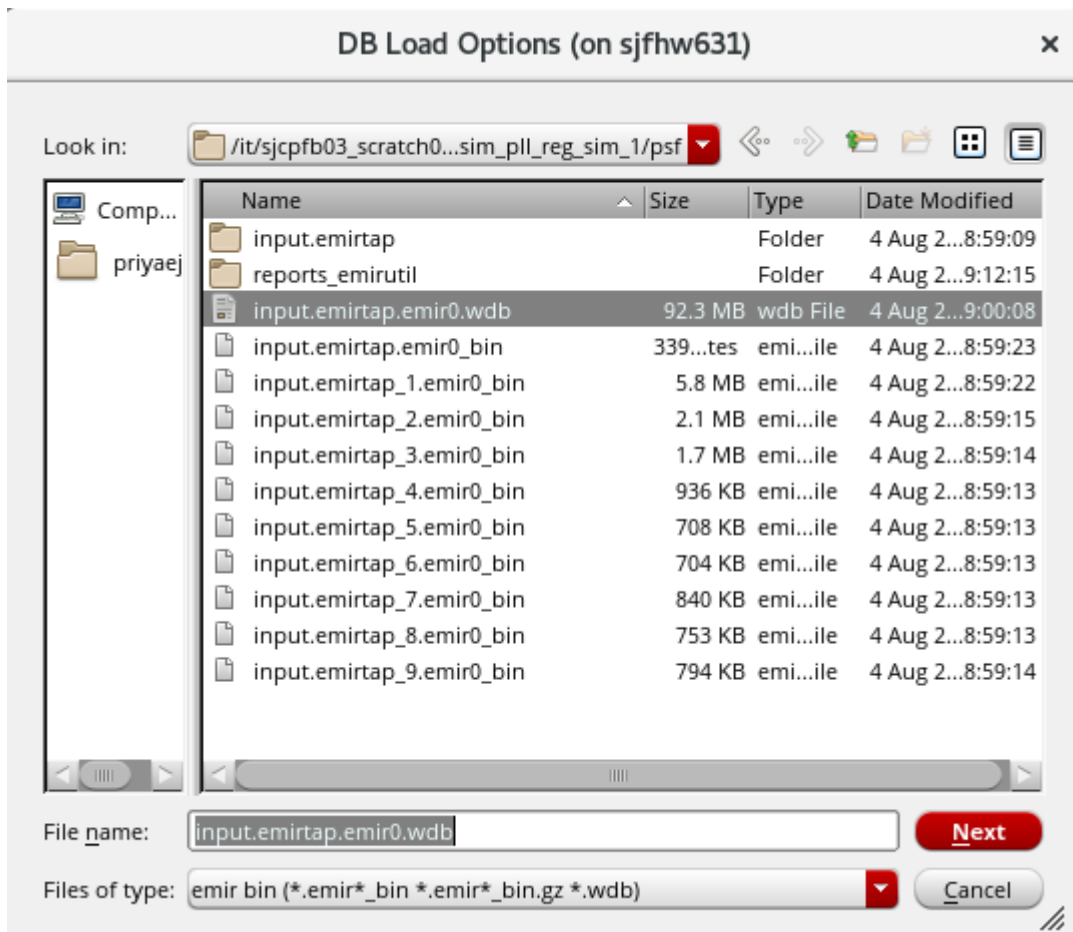

Voltus-XFi Custom Power Integrity Solution User Guide

Viewing EM-IR Analysis Results

2. Select the .wdb database and click *Next*.

The DB Load Options form appears.

DB Load Options (on sjfhw631)

WDB Metrics

Metric	Value
File Size	39.66M
Analysis	SPGS
Net Count	4

General IR EM SPGS

Cache Nets

Load Only Selected Layers

Update Net Summary Metrics

Load	Layer
<input type="checkbox"/>	Cont
<input checked="" type="checkbox"/>	Metal1
<input checked="" type="checkbox"/>	Metal2
<input checked="" type="checkbox"/>	Metal3
<input type="checkbox"/>	Metal4
<input type="checkbox"/>	Metal5
<input type="checkbox"/>	Metal6
<input type="checkbox"/>	Metal7
<input checked="" type="checkbox"/>	Oxide
<input checked="" type="checkbox"/>	Via1

3. Select the *Cache Nets* option to keep the loaded nets in memory.
4. Select the *Load Only Selected Layers* option to enable the loading of selected layers for the loaded nets.
5. Select the *Update Net Summary Metrics* option to display metrics only for the selected layers in the *Net Summary* section of the Voltus-XFi Results Browser assistant.

Voltus-XFi Custom Power Integrity Solution User Guide

Viewing EM-IR Analysis Results

6. Enable or disable any of the layers individually by selecting the checkboxes next to them in the *Load* column.

The layers table shows the DFII names if you have set the DFII layer map file using the `dfIILayerMapFile` variable. If this variable is not specified, the table shows the DSPF layer names.

7. Click the *IR* tab.

This tab will be enabled only after performing the static/dynamic IR analysis.

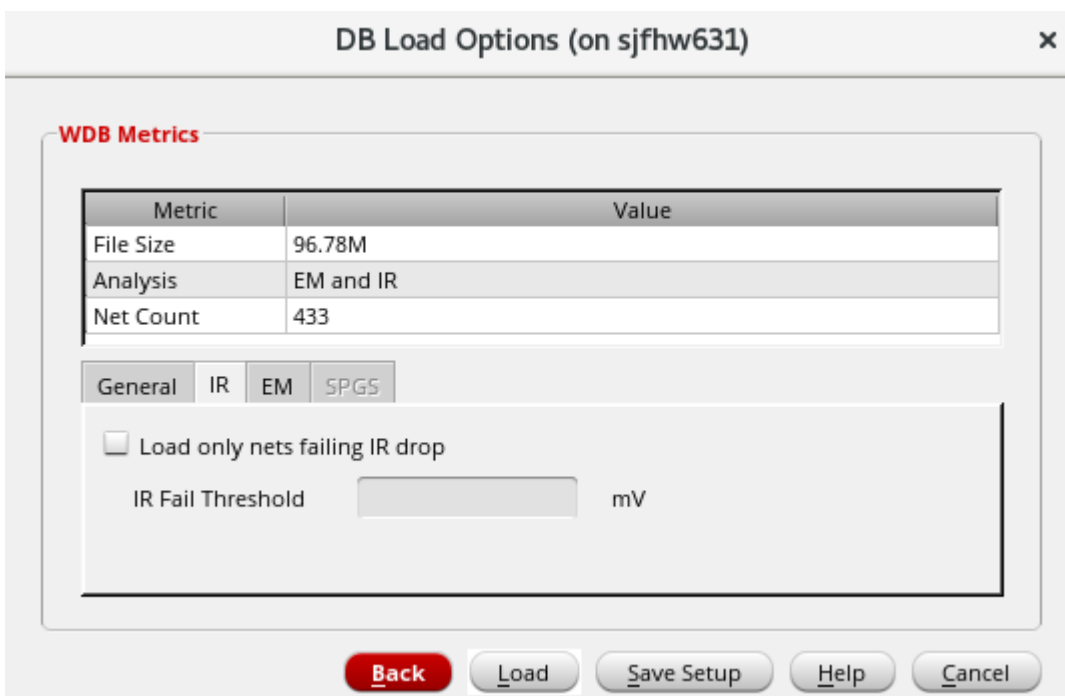

8. Select the *Load only nets failing IR drop* option and then enter a value in the *IR Fail Threshold* field to load nets with IR drop higher than the specified value.
9. Specify the threshold value in the *IR Fail Threshold* field.
10. Click the *EM* tab.

This tab will be enabled only after performing the static/dynamic EM analysis.

Voltus-XFi Custom Power Integrity Solution User Guide

Viewing EM-IR Analysis Results

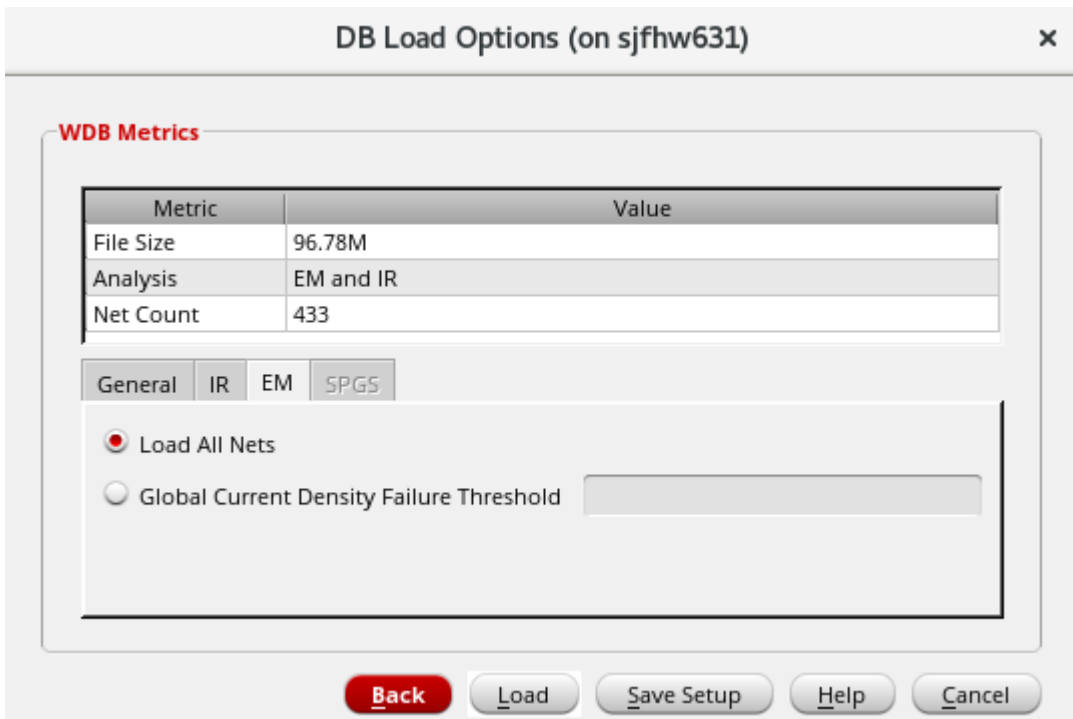

11. Select the *Load All Nets* option to display all signal nets. Alternatively, you can specify a threshold value in the *Global Current Density Failure Threshold* field to only load the nets with a current density value more than the specified threshold value.

Important

If you specify both the IR and EM threshold values, then only those nets that pass both criteria will be loaded.

12. Click the *SPGS* tab.

This tab will be enabled only after performing the SPGS analysis.

Voltus-XFi Custom Power Integrity Solution User Guide

Viewing EM-IR Analysis Results

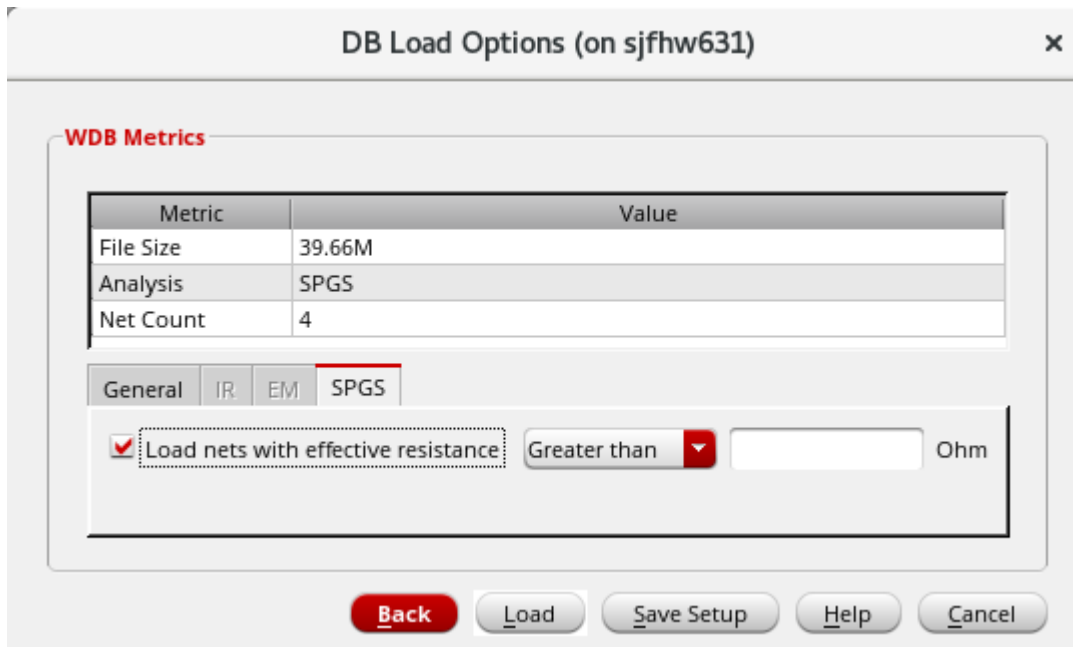

13. Select the *Load nets with effective resistance* option to display metrics only for the nets with the resistance value greater than/less than the value entered in the text field.
14. Click *Save Setup* to save the setting.

The settings will be saved in the .json file format at `'.cadence/dfII/tungsten/ResultsLoadSettings.json'`. The default file name is `ResultsLoadSettings.json`. This file can be modified by either updating and saving the settings in GUI or manually editing the .json file. You can use the `loadResultsSettingsFile` environment variable to load the saved .json file.

15. Click *Load* to load the results according to the saved settings.

Displaying and Hiding Voltus-XFi Results Browser

To display the results browser in the Virtuoso Layout window:

- Choose *Window – Assistants – Voltus-XFi Results Browser*.

Once selected, the results browser assistant is added as a docked assistant pane within the current layout window. By default, the assistant is positioned at the right side of the session window.

To hide the assistant:

- Choose *Window – Assistants - Voltus-XFi Results Browser*.

Related Topics

- [The Voltus-XFi Results Browser Graphical User Interface](#)
- [Visualizing EM-IR Analysis Results using Voltus-XFi Results Browser](#)

Visualizing EM-IR Analysis Results using Voltus-XFi Results Browser

You can analyze the EM and IR drop violations in detail using the Voltus-XFi Results Browser assistant. Do the following:

1. On the *Voltus-XFi Results Browser*, click *Load EMIR Results* to load the results database.
2. Select a net in the Net Summary (top) section and click *Load Nets* . Alternatively, you can either double-click a net name or select the *Load Nets* option from the shortcut menu of the net to view net details.

Note: You can select one or multiple nets in the Net Summary section.

Details of all nodes/resistors/paths of the net appear in the lower section of the assistant as follows:

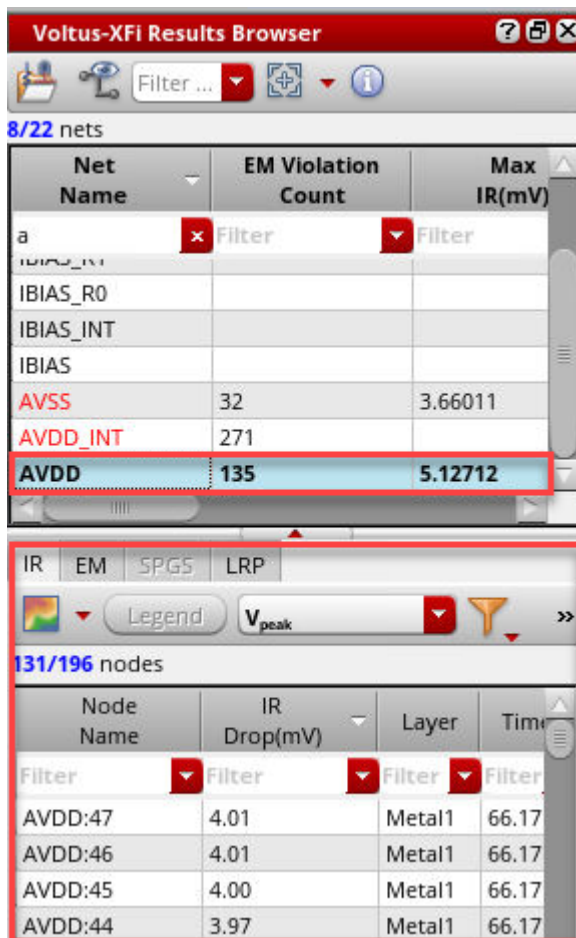

Voltus-XFi Custom Power Integrity Solution User Guide

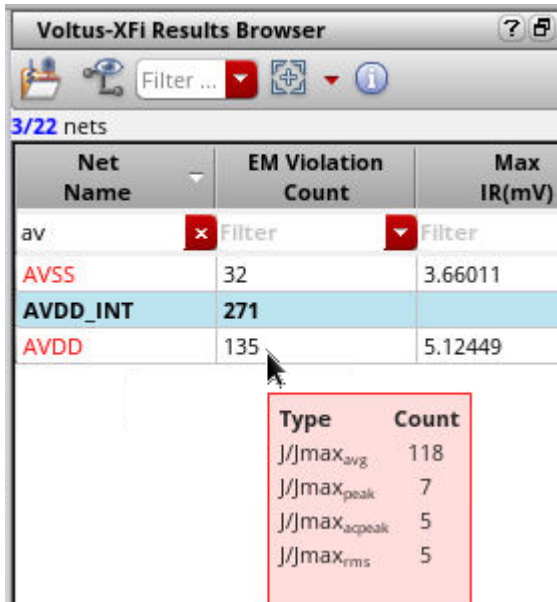

Viewing EM-IR Analysis Results

If you mouseover the *EM Violation Count* column in the Net Summary section, a tooltip appears showing you the violations for each EM analysis type.



Net Name	EM Violation Count	Max IR(mV)
av	Filter	Filter
AVSS	32	3.66011
AVDD_INT	271	
AVDD	135	5.12449

Type	Count
J/Jmax _{avg}	118
J/Jmax _{peak}	7
J/Jmax _{speak}	5
J/Jmax _{rms}	5

3. Depending on whether you want to view the EM or IR drop plots, select the required tab in the lower section of the assistant.
4. Click the *Plot Results* () icon to view the heat map plot for the complete net. You can use the down arrow to adjust the transparency of the layout.
5. Select a plot type from  drop-down list.
6. Select a node/resistor in the lower section of the assistant.

Voltus-XFi Custom Power Integrity Solution User Guide

Viewing EM-IR Analysis Results

The node/resistor is highlighted on the layout. The following image shows a node selected in the *IR* tab.

The screenshot displays a PCB layout with an IR analysis overlay. A node is highlighted, and a tooltip shows the following details:

- Node Name: AVDD:105
- IR Drop(mV): 0.45
- Layer: Metal1
- DSPF Layer: metal1_conn
- Time: 66.17n

The results table on the right shows the following data:

Net Name	EM Violation Count	Max IR(mV)
IBIAS_INT		
IBIAS_R0		
IBIAS_INT		
IBIAS		
AVSS	32	3.66011
AVDD_INT	271	
AVDD	135	5.12712

Node Name	IR Drop(mV)	Layer	Time
AVDD:34	0.45	Metal1	66.17
AVDD:105	0.45	Metal1	66.17
AVDD:124	0.45	Metal1	51.17
AVDD:125	0.45	Metal1	51.17

You can view the layer-based heatmap by clicking the *Filter Layer from Results* drop-down button in the *IR* or *EM* tab, select *Hide All Layers*, and then select the required layers.

Voltus-XFi Custom Power Integrity Solution User Guide

Viewing EM-IR Analysis Results

The following image shows a resistor selected in the *EM* tab.

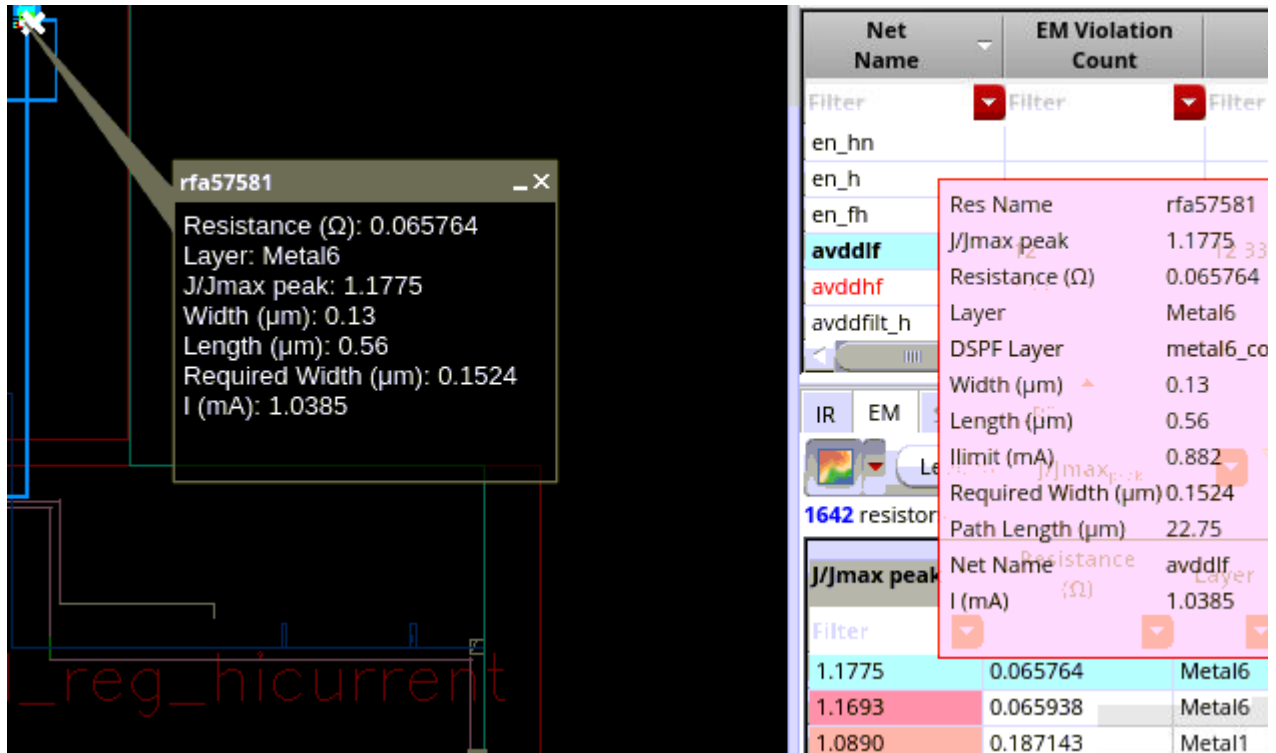

The *EM* tab shows resistors that violate EM in red to easily identify EM violations.



Related Topics

- [The Voltus-XFi Results Browser Graphical User Interface](#)
- [Performing LRP Analysis](#)
- [Viewing EM-IR Analysis Reports](#)
- [Viewing Waveform Results](#)
- [Querying Specific Areas and Shapes in the Layout for Node/Resistor Information](#)

Querying Specific Areas and Shapes in the Layout for Node/Resistor Information

Select  in the IR/EM Analysis toolbar of Voltus-XFi Results Browser to display the resistor/node information within a specified area or a shape in the layout.

To select a query area:

1. Click  and select *Query Area* from the drop-down list.
2. Click the  button.
3. Left-click and select an area in the layout. The result of the query or the node/resistor information for the selected area is displayed in the *IR Drop/EM* tabs of the Results browser.

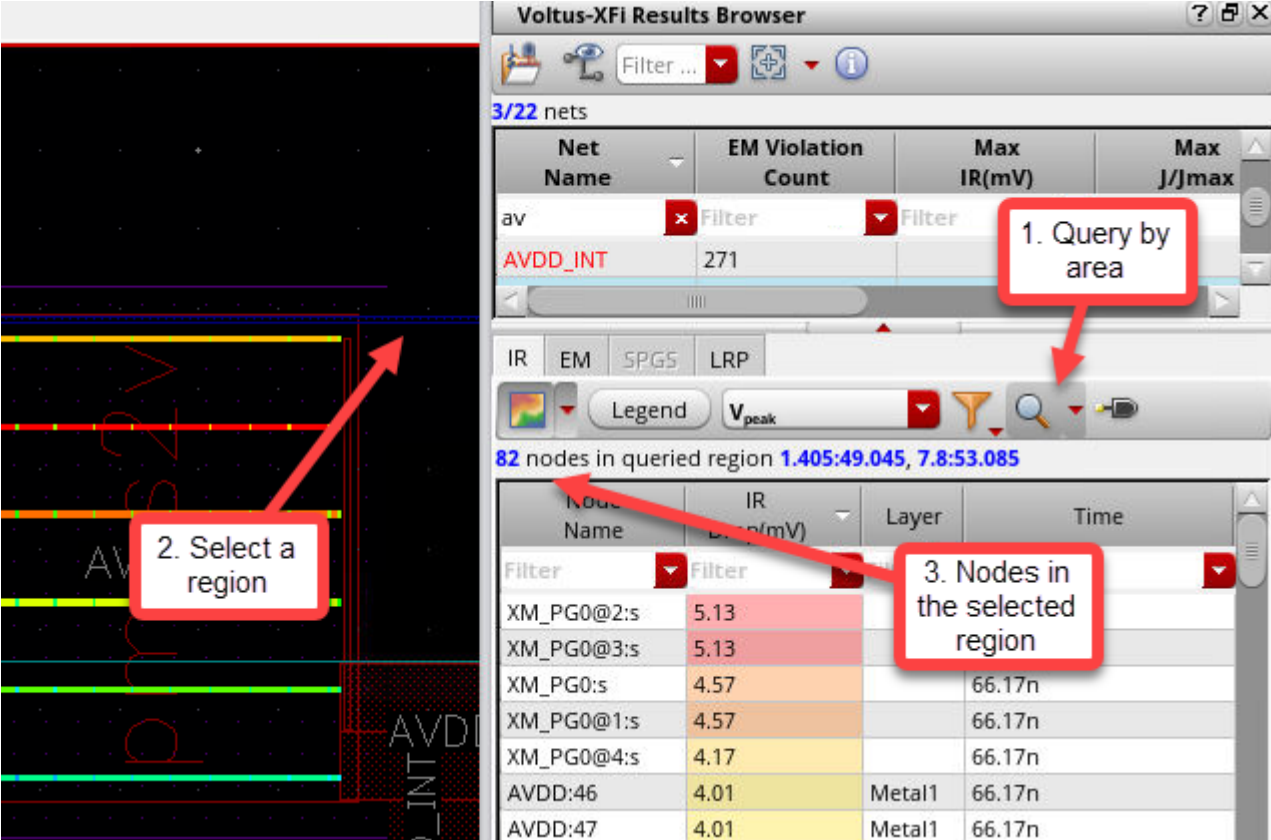

The screenshot shows the Voltus-XFi Results Browser interface. On the left, a layout view displays a red rectangular query area over a circuit board layout. Three red callout boxes with arrows point to specific parts of the interface:

- Box 1: "1. Query by area" points to the search icon in the toolbar.
- Box 2: "2. Select a region" points to the red query area on the layout.
- Box 3: "3. Nodes in the selected region" points to the node information table.

The Results Browser window displays the following data:

3/22 nets

Net Name	EM Violation Count	Max IR(mV)	Max J/Jmax
av	Filter	Filter	
AVDD_INT	271		

IR EM SPGS LRP

Legend V_{peak}

82 nodes in queried region 1.405:49.045, 7.8:53.085

Node Name	IR Drop(mV)	Layer	Time
Filter	Filter		
XM_PG0@2:s	5.13		
XM_PG0@3:s	5.13		
XM_PG0:s	4.57		66.17n
XM_PG0@1:s	4.57		66.17n
XM_PG0@4:s	4.17		66.17n
AVDD:46	4.01	Metal1	66.17n
AVDD:47	4.01	Metal1	66.17n

Voltus-XFi Custom Power Integrity Solution User Guide

Viewing EM-IR Analysis Results

To select a query shape:

1. Click  and select *Query Shape* from the drop-down list.

Query shape is enabled only when you have specified the `dfllayermapfile` in `cdsenv/cdsinit`.

2. Click the  button.

3. Left-click and select a shape in the layout. The result of the query or the node/resistor information for the selected shape is displayed in the *IR Drop/EM* tabs of the Results browser.

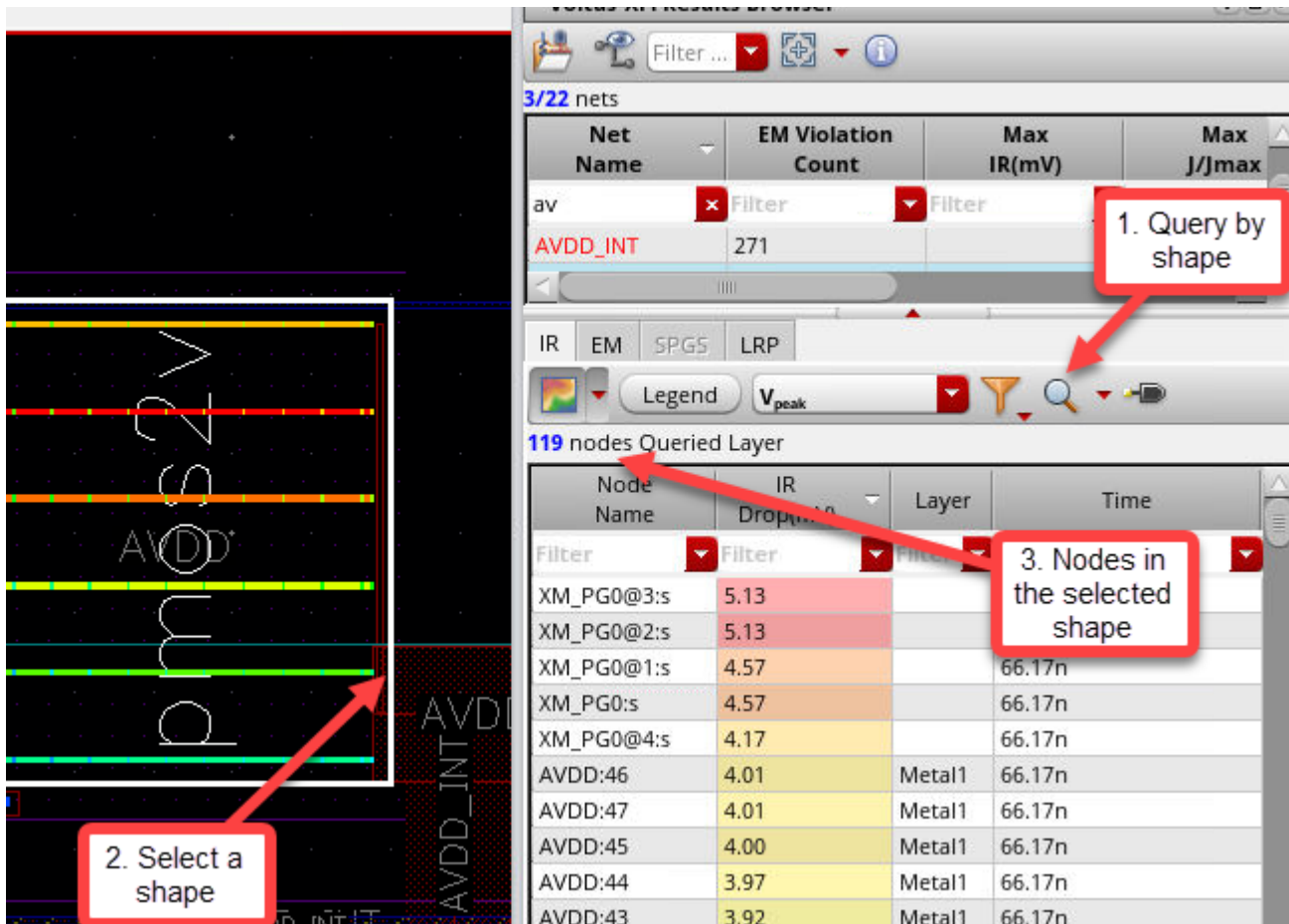

3/22 nets

Net Name	EM Violation Count	Max IR(mV)	Max J/Jmax
av	271		
AVDD_INT	271		

IR EM SPGS LRP

Legend V_{peak}

119 nodes Queried Layer

Node Name	IR Drop	Layer	Time
XM_PG0@3:s	5.13		
XM_PG0@2:s	5.13		
XM_PG0@1:s	4.57	66.17n	
XM_PG0:s	4.57	66.17n	
XM_PG0@4:s	4.17	66.17n	
AVDD:46	4.01	Metal1	66.17n
AVDD:47	4.01	Metal1	66.17n
AVDD:45	4.00	Metal1	66.17n
AVDD:44	3.97	Metal1	66.17n
AVDD:43	3.92	Metal1	66.17n

2. Select a shape

1. Query by shape



3. Nodes in the selected shape

Related Topics

- [The Voltus-XFi Results Browser Graphical User Interface](#)
- [Visualizing EM-IR Analysis Results using Voltus-XFi Results Browser](#)

Performing LRP Analysis

You can view the LRP plot for a net using the Voltus-XFi Results Browser assistant. Perform the following steps after loading the IR drop analysis results:

1. Select a net for which you want to perform the LRP analysis in the Net Summary (top) section and click *Load Nets*. .
2. In the LRP tab, click *Shorted Layers*  to short specific layers for LRP analysis.
3. Click *Compute LRP*  to compute LRP values for all nodes of the selected net.

The LRP information is populated in the *Starting Node*, *Node ID*, and *Resistance* columns of the *paths* table in the *LRP* tab.

4. Select a node in the paths table to view its LRP in the layout. When a node is clicked, the LRP path is highlighted in white in the Virtuoso layout.

Voltus-XFi Custom Power Integrity Solution User Guide

Viewing EM-IR Analysis Results

5. In the resistors table of the *LRP* tab, you can view the list of resistors for a path. The LRP path is highlighted with a white border and the resistor from the path is highlighted in red, as shown below:

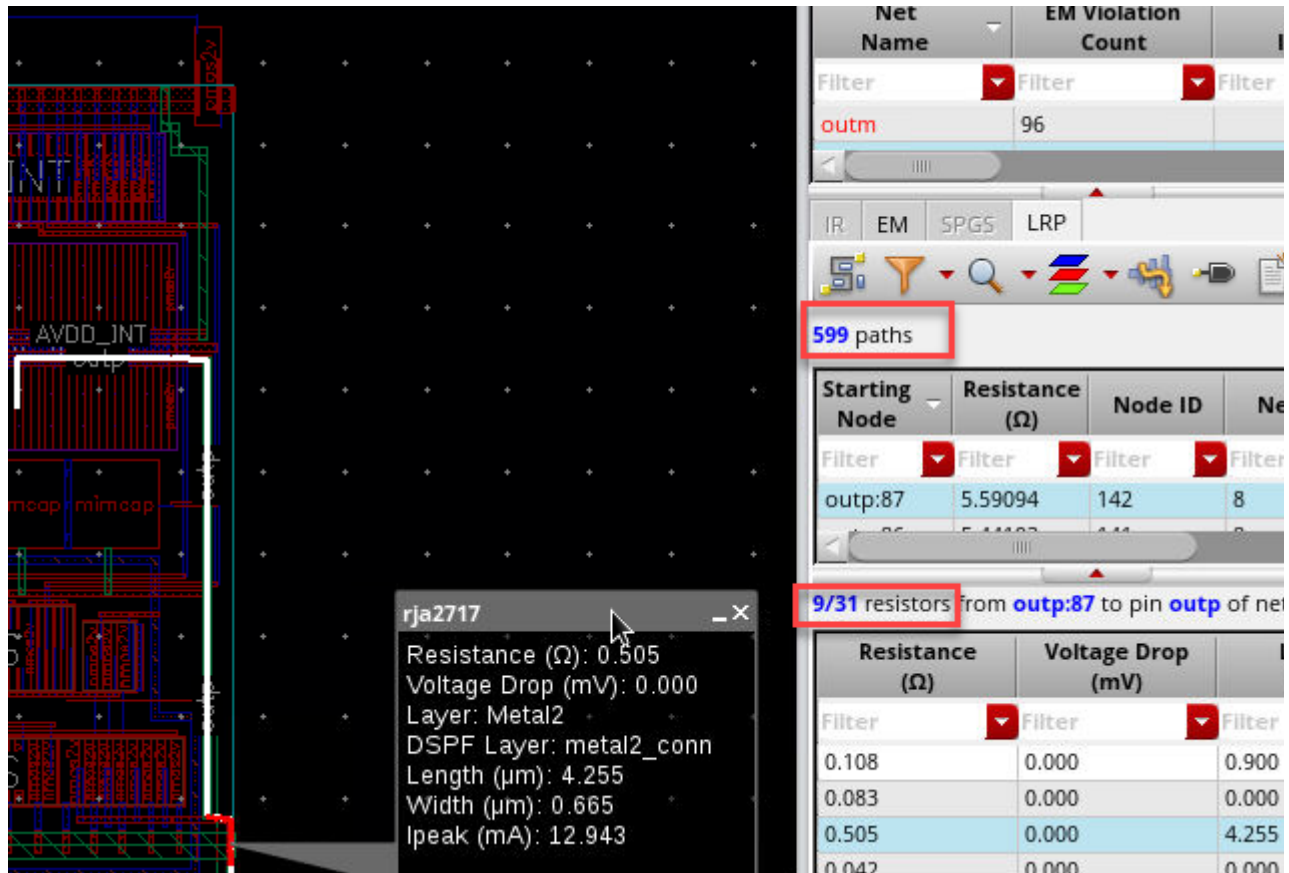

Related Topics

- [The Voltus-XFi Results Browser Graphical User Interface](#)
- [Visualizing EM-IR Analysis Results using Voltus-XFi Results Browser](#)
- [Shorting Layers for LRP Analysis](#)
- [Selecting a Node for LRP Analysis from the IR Tab](#)

Shorting Layers for LRP Analysis

While computing LRP for a node or instance, you can short specific layers. When you do this, all resistors on the specified layer are shorted, that means, the LRP has a value of 0 for all resistors on the shorted layer.

When you click *Shorted Layers*  , a pop-up window opens displaying the list of layers. In this window, select the layer you want to short and click *Compute LRP*. You can short multiple layers. Each time the list of shorted layers is modified, click *Compute LRP* to recalculate LRP.

For example, in the image below, layer Metal2 is shorted.



When a layer is shorted, the layer information for the shorted layer is not displayed in the resistance path table. For example, in the image below, the resistance value for node AVDD:166 is included before shorting Metal2:

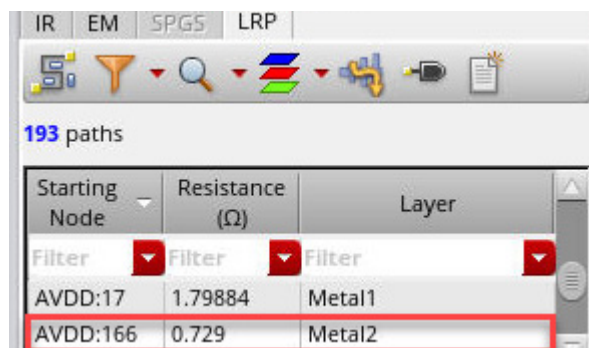

Voltus-XFi Custom Power Integrity Solution User Guide

Viewing EM-IR Analysis Results

After Metal2 is shorted, the node AVDD:166 is not displayed in the table:

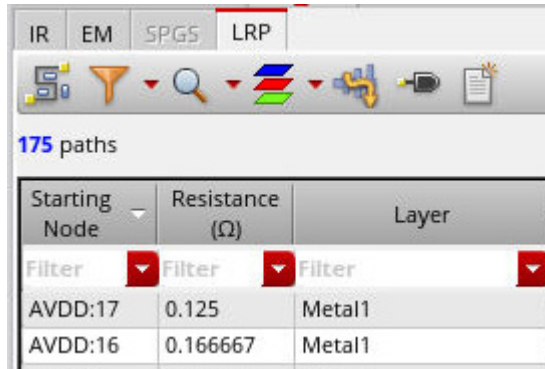

Starting Node	Resistance (Ω)	Layer
Filter	Filter	Filter
AVDD:17	0.125	Metal1
AVDD:16	0.166667	Metal1

Related Topics

- [The Voltus-XFi Results Browser Graphical User Interface](#)
- [Performing LRP Analysis](#)
- [Visualizing EM-IR Analysis Results using Voltus-XFi Results Browser](#)

Selecting a Node for LRP Analysis from the IR Tab

You can select any node for LRP analysis directly from the *IR* tab. After loading the nodes of a net, right-clicking a node displays the *Compute LRP* option.

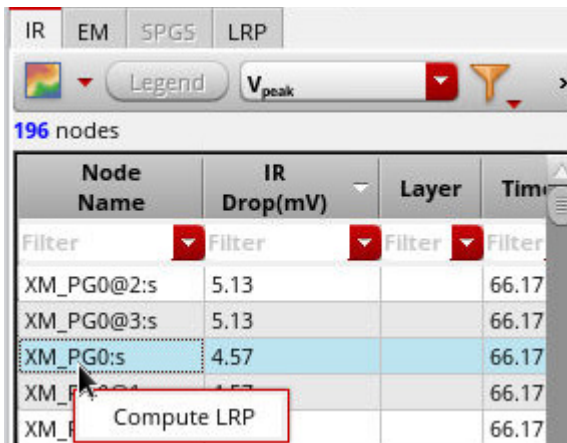

When *Compute LRP* is selected, the *LRP* tab opens and displays the selected node and the calculated LRP resistance from pin to that particular node.

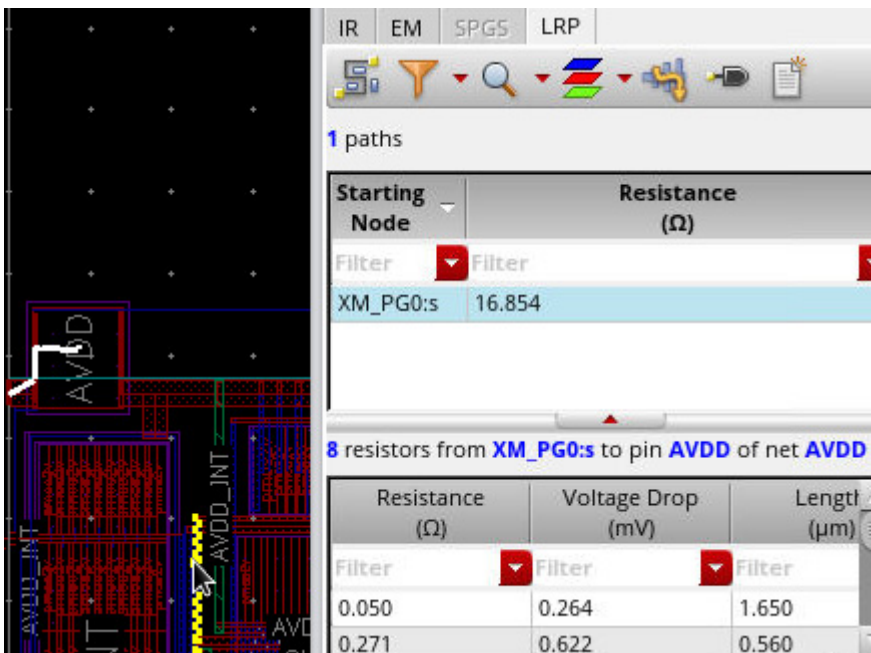

Related Topics

- [Performing LRP Analysis](#)

Viewing Detailed Electromigration Information

To see more information about the electromigration parameters, right-click a resistor in the *EM* tab of the Voltus-XFi Results Browser assistant and select the *Detailed EM Info* option. This option will be enabled only if the *Detailed Information* check box is selected in the *Setup – Electromigration* tab of the tungsten view.

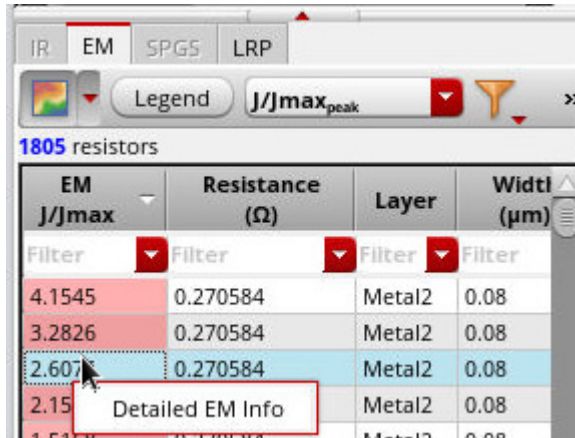

When *Detailed EM Info* is selected, the *EM Detailed Information* window opens and displays the EM details of the selected resistor.

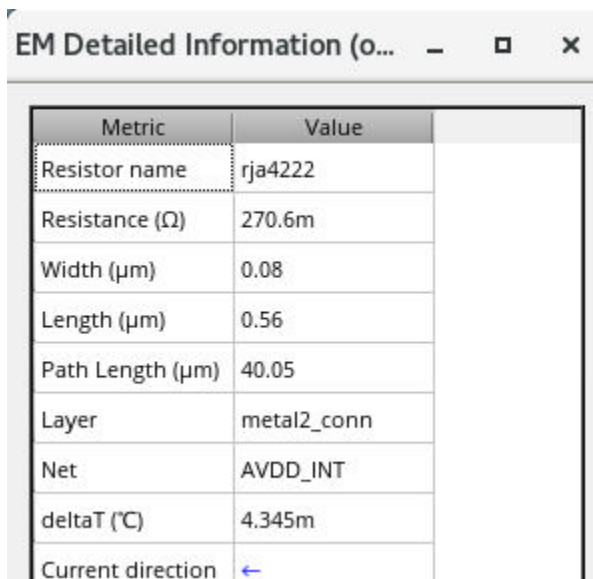

To view and compare EM details of multiple resistors in the same *EM Detailed Information* window, right-click the required row in the *EM* tab and click *Detailed EM Info* again. This step should be repeated for each resistor that you want to view.

Voltus-XFi Custom Power Integrity Solution User Guide

Viewing EM-IR Analysis Results

Related Topics

- [Visualizing EM-IR Analysis Results using Voltus-XFi Results Browser](#)
- [Querying Specific Areas and Shapes in the Layout for Node/Resistor Information](#)

Viewing the Thermal Delta-T Plots

There are two self-heating effect analysis and thermal-aware DC EM analysis plots that are available:

- ❑ Thermal-DeltaT Regions - Reports the increase in temperature (deltaT) for all OD layers in the entire design on the Virtuoso layout. This plot provides a detailed view of the temperature variations on the design.
- ❑ Thermal-DeltaT Tiles - Reports the increase in temperature (deltaT) per tile based on the number of tiles, specified in the Setup – Electromigration Tab of the Voltus-XFi UI. For this plot, you can specify the dimensions for the tiles in the Tiles field. The design in the layout is divided into sections based on the number of tiles that are specified, for example, 15x20. The default is 10x10.

You can view the thermal delta-T plot for a net using the Voltus-XFi Results Browser assistant. Perform the following steps after loading the analysis results:

1. Select a net for which you want to view the thermal data in the Net Summary (top) section and click *Load Nets*. .
2. In the *EM* tab, select an SHE plot type from the EM plots drop-down list.

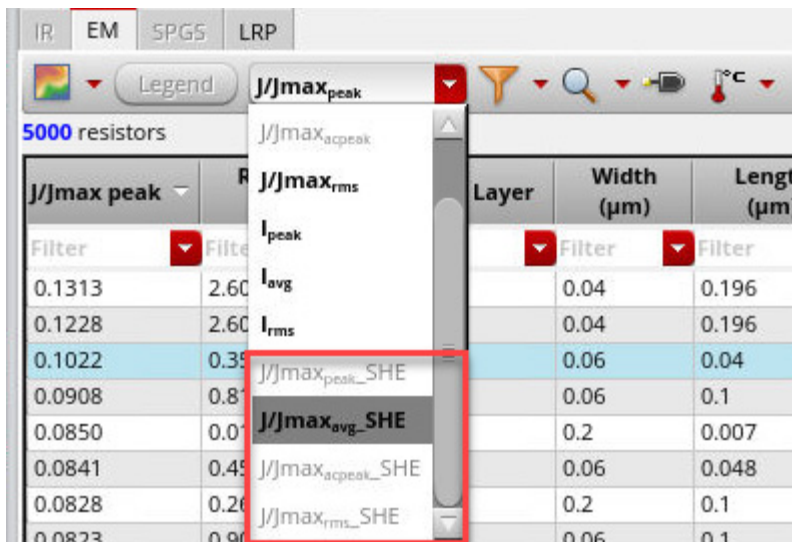

3. Click *Thermal Plots*  to enable the display of thermal data.

The thermal data will be displayed in a new table below the EM table.

Voltus-XFi Custom Power Integrity Solution User Guide

Viewing EM-IR Analysis Results

4. Select the plot type by clicking on either the *Region Plot* or *Tile Plot* option from the *Thermal Plots* drop-down list. The *Region Plot* is selected by default.



- ❑ For the region plot, the table shows the following columns: *Region T Rise*, *Instance Name*, *Instance T Rise*, *Instance Location*, *Region*, and *Region ID*. On selecting an instance in the table, the instance location will be displayed as a cross mark (X) and the region around it will be highlighted, as shown below.



You can right-click a row in the thermal data table and click *Show All Instances in the Region* option. All the instances of the specific OD region will be displayed, as shown below.

Region T Rise (°C)	Instance Name	Instance T Rise (°C)	Instance Location
Filter	Filter	Filter	Filter
3.77916	../M0_unmatched	4.82	5.633:1.9
3.77916	../M0_unmatched	0.07855	7.571:1.9
3.77916	../M0_unmatched	0.4958	7.343:1.9
3.77916	X		2.783:1.9
3.77916			7.115:1.9

↓

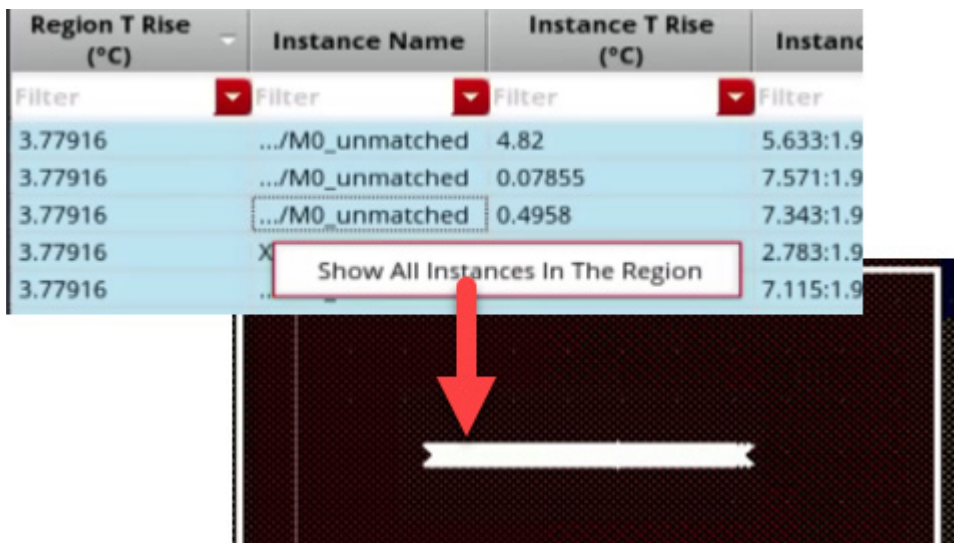
A screenshot of a thermal data table with a right-click context menu open over a row. The menu has one option: 'Show All Instances In The Region'. A red arrow points from the menu option to a white arrow pointing to a region in the thermal plot below.

Voltus-XFi Custom Power Integrity Solution User Guide

Viewing EM-IR Analysis Results

- For the tile plot, the table shows the following columns: *Region T Rise*, *Tile Row Number*, *Tile Column Number*, and *Region*. On selecting a row in the table, the tile will be highlighted, as shown below.



Related Topics

- [Viewing Detailed Electromigration Information](#)
- [Visualizing EM-IR Analysis Results using Voltus-XFi Results Browser](#)
- [Querying Specific Areas and Shapes in the Layout for Node/Resistor Information](#)



Customizing the Range for Viewing Violations

The *Legend* button in the Voltus-XFi Results Browser lets you customize the range of violations you want to view and control the display of plots. This data filtering feature via the *Legend* button is available for the IR, EM, and SPGS analyses.

There are two types of legends, sliders and buckets:

- The slider or color gradient based filter allows you to modify the minimum and maximum violation values by moving the Min - Max sliders up and down. This legend type appears for the *IR* tab voltage plots and *SPGS* tab.
- The bucket or color range based filter allows you to modify 6 equal filters or buckets between the minimum and maximum values. This legend type appears for the *IR* tab current plots and *EM* tab.

To customize the filter range for the *IR* tab voltage plots and SPGS tab:

1. Select a net for which you want to perform the analysis in the Net Summary (top) section and click *Load Nets*. .
2. In the *IR/SPGS* tab, click the *Plot Results* () icon to view the heat map plot for the complete net.
3. Click *Legend* to open the Legend window.

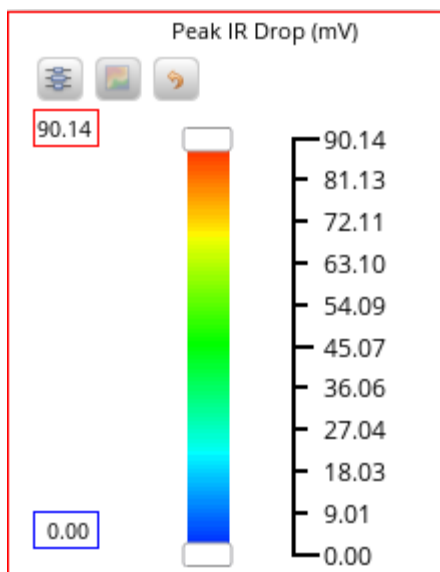

Voltus-XFi Custom Power Integrity Solution User Guide

Viewing EM-IR Analysis Results

4. Move the Min - Max sliders up and down to view violations that fall within the required slider range. You can also enter the maximum and minimum violation values in the red and blue text boxes on the left side of the sliders.

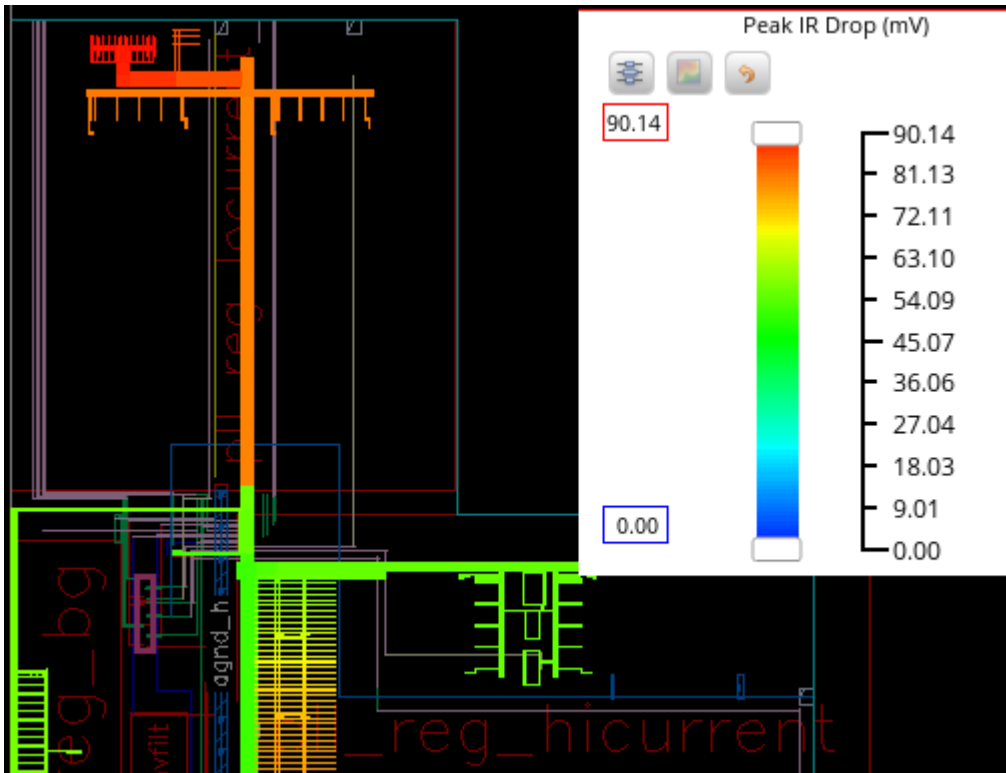

The display highlights are updated according to the new slider positions. The following images display the layout before and after moving the Min - Max sliders.

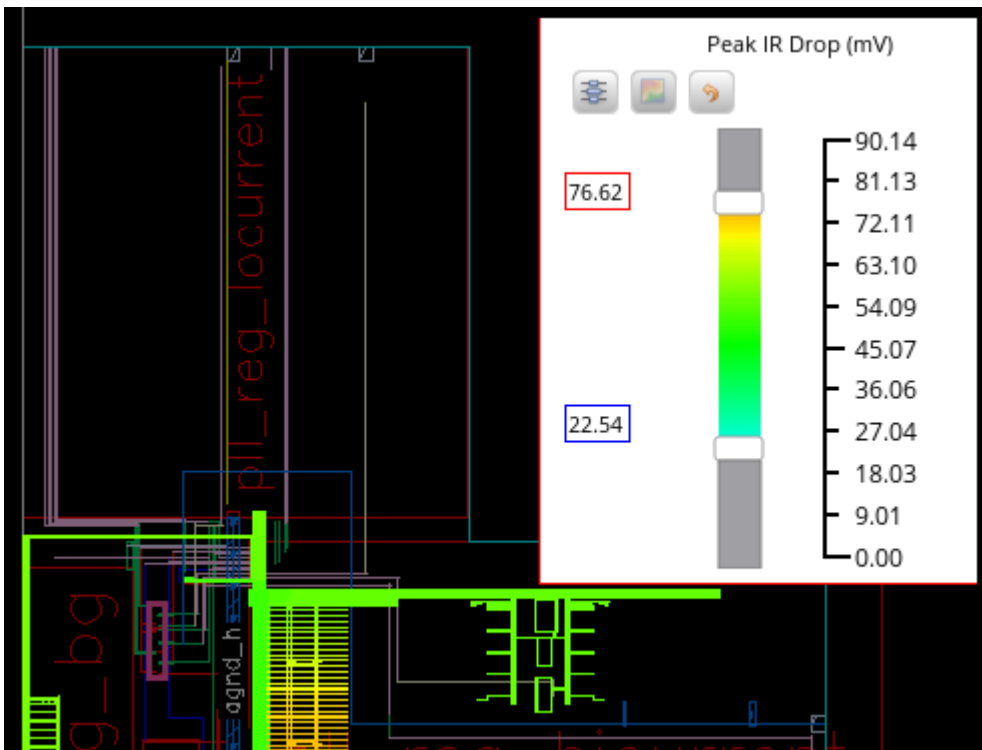

Voltus-XFi Custom Power Integrity Solution User Guide

Viewing EM-IR Analysis Results





5. You can click the *Redistribute the values between selected ranges*  button to view the complete spectrum, from “deep red” to “deep blue”, for the specified range.
6. You can click the *Plot out of range values*  button to view the violation values outside the redistributed Min - Max slider range. For example, if the redistributed range is between “69.41” and “17.13”, and *Plot out of range values* is enabled, the violations above and below the slider marks are also displayed in “deep red” and “deep blue”, respectively.

The following image shows A. Move Min - Max Slider Range, B. Redistributed Range and C. Plot Out of Range

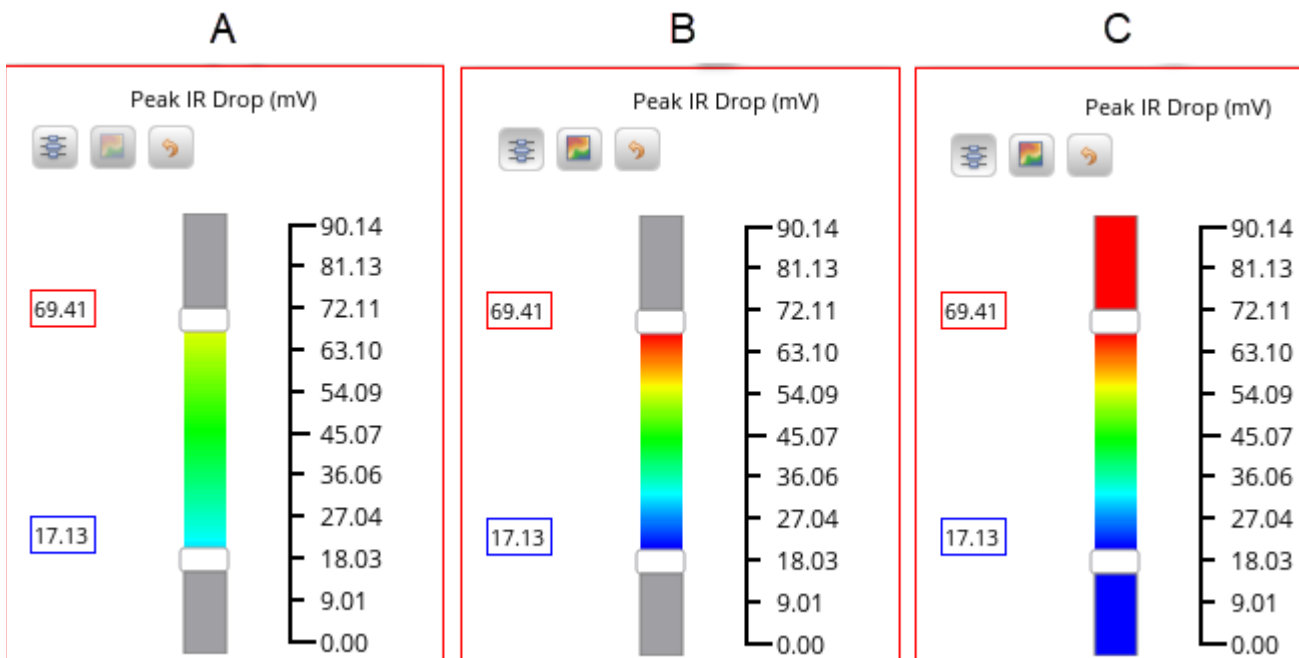

Voltus-XFi Custom Power Integrity Solution User Guide

Viewing EM-IR Analysis Results



7. You can click the *Reset*  button to restore the default values of filters in the *Min* and *Max* fields.

To customize the maximum and minimum value of a data range for the *IR* tab current plots and *EM* tab:

1. Select a net for which you want to perform the EM analysis in the Net Summary (top) section and click *Load Nets*. .
2. In the *EM* tab, click the *Plot Results* () icon to view the heat map plot for the complete net.
3. Click *Legend* to open the Legend window.

Voltus-XFi Custom Power Integrity Solution User Guide

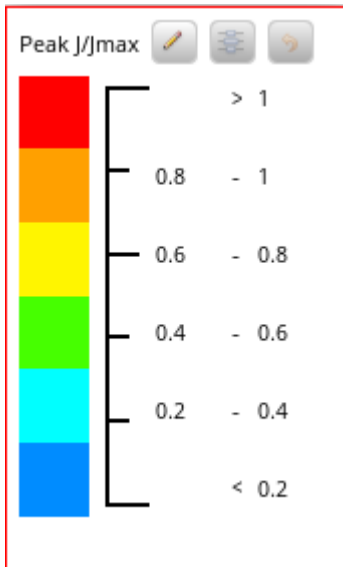

Viewing EM-IR Analysis Results

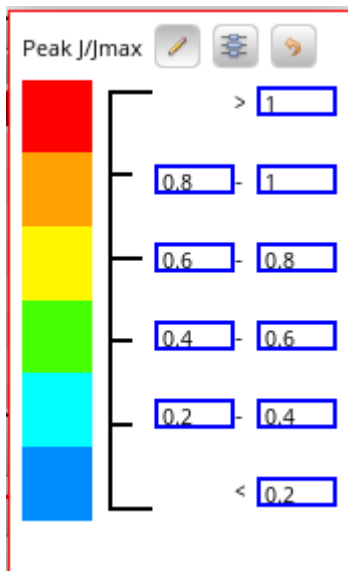

4. Click the *Customize*  button to specify the minimum and maximum value for a specific color/data range.

The Legend window appears in the editable form:



5. Click the *Redistribute ranges*  button to redistribute the range based on the specified minimum and maximum values.
6. You can click the *Restore default ranges*  button to restore the default values of each data/color range.

Voltus-XFi Custom Power Integrity Solution User Guide

Viewing EM-IR Analysis Results

Related Topics

- [Viewing Detailed Electromigration Information](#)
- [Visualizing EM-IR Analysis Results using Voltus-XFi Results Browser](#)

Loading and Viewing Nets from a Power Gate Group

Power networks may contain power gates which enable or disable the power supply in the circuit. These power gates split the power supply RC network into two parts. The RC network driving the power gate, and the RC network being driven by the power gate. This is shown in the figure below. The Voltus-XFi EM-IR analysis can handle such power gates.

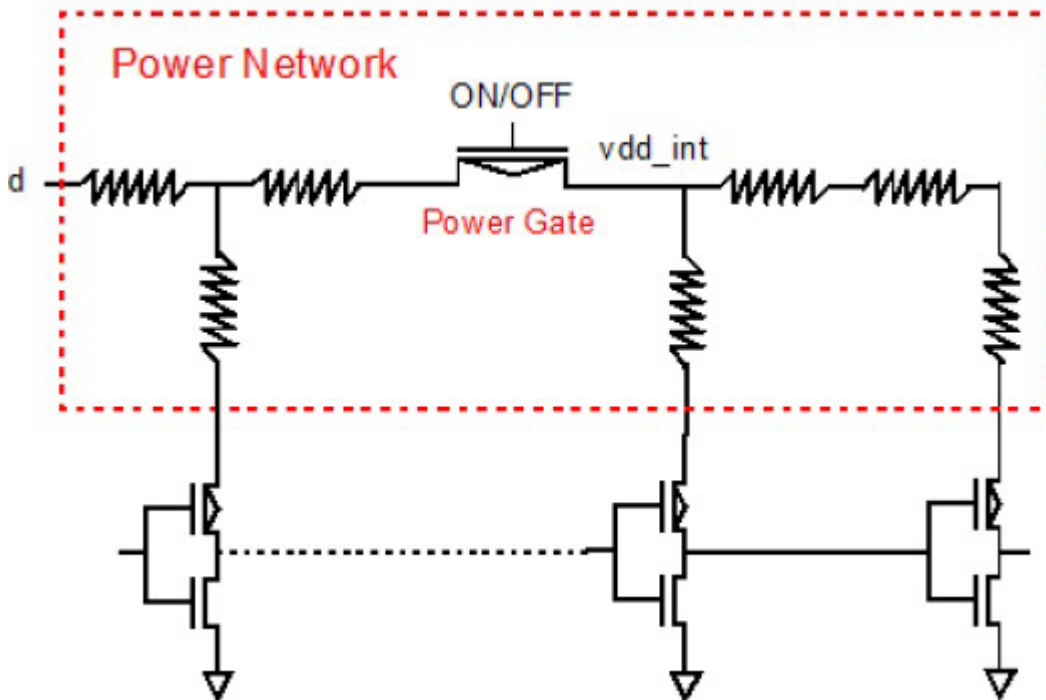

Both, the power supply net (vdd) driving the power gates, and the internal power supply net (vdd_int) driven by the power gates, need to be grouped in the *Setup – Power Nets* tab of the tungsten view.

When you select a net that is part of power-gated group of nets, you can either load all the nets of that group or just the selected net. To load and view a power gate group:

1. Select any net that is part of a power gate group of nets in the Net Summary (top) section and click *Load Nets*. .

Voltus-XFi Custom Power Integrity Solution User Guide

Viewing EM-IR Analysis Results

A confirmation message appears asking you if you want to load all nets of a power gate group or only the selected net.

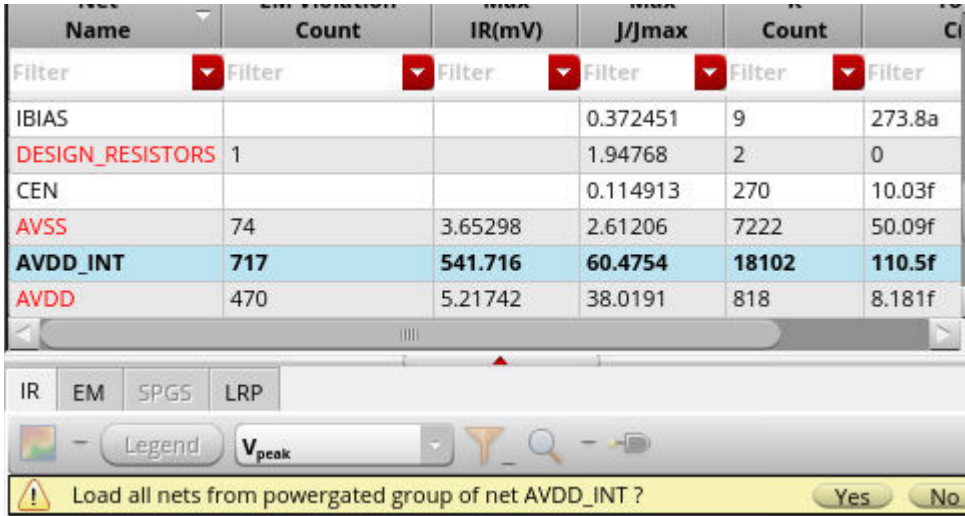

The screenshot displays a table with the following data:

Name	Count	IR(mV)	J/Jmax	Count	Count
IBIAS			0.372451	9	273.8a
DESIGN_RESISTORS	1		1.94768	2	0
CEN			0.114913	270	10.03f
AVSS	74	3.65298	2.61206	7222	50.09f
AVDD_INT	717	541.716	60.4754	18102	110.5f
AVDD	470	5.21742	38.0191	818	8.181f

Below the table, a confirmation dialog box is visible with the text: "Load all nets from powergated group of net AVDD_INT ?" and "Yes" and "No" buttons.

2. Click *Yes* to load all nets.
3. Click *Plot Results*.
4. Right-click the column header to select the *Net Name* column and view the net to which the node or resistor belongs.

Related Topics

- [Viewing EM-IR Analysis Results](#)
- [Visualizing EM-IR Analysis Results using Voltus-XFi Results Browser](#)
- [Querying Specific Areas and Shapes in the Layout for Node/Resistor Information](#)

Viewing EM-IR Analysis Reports

By default, Voltus-XFi generates the following reports for EM-IR analysis:

- Summary report (`summary.rpt`), which includes reports for all analyses (IR drop and EM) performed in the current run
- IR drop analysis report with the extension, `*.rpt_ir`
- EM analysis report with the extension, `*.rpt_em`
- Unmatched resistors report with the extension, `*.rpt_unmatch`
- Pin current report with the extension, `*.rpt_pin`

To view the EM-IR analysis reports, do the following:

1. On the Voltus-XFi window, choose *Results* from the task pane.
2. Select an analysis, test, and corner for which you want to view the reports.
3. Select the *Reports* tab.

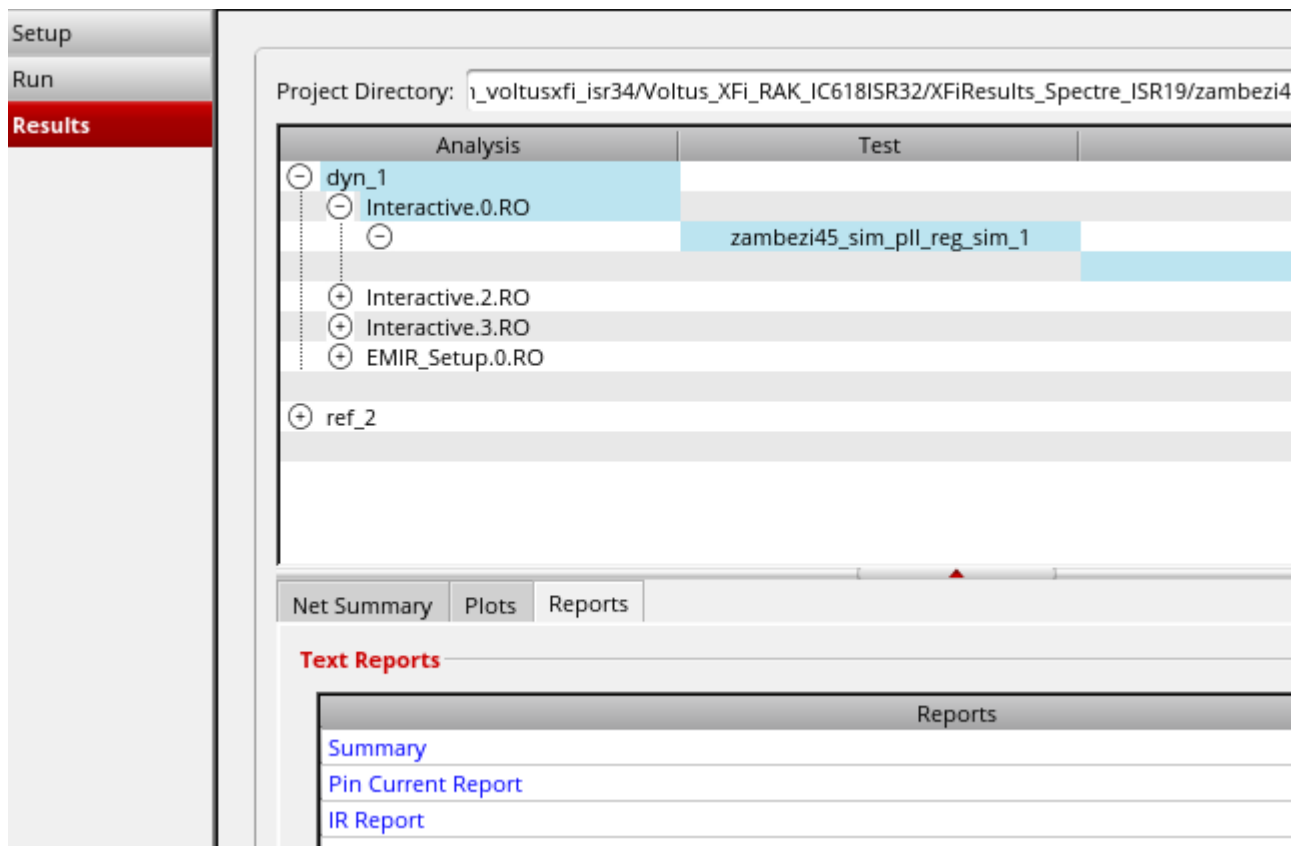

Voltus-XFi Custom Power Integrity Solution User Guide

Viewing EM-IR Analysis Results

4. In the *Text Reports* section, click on a report that you want to view under the *Type* column.

The selected report is displayed in a separate window.

Related Topics

- [Summary Report](#)
- [IR Report](#)
- [EM Report](#)
- [Unmatched Resistor Report](#)
- [Pin Current Report](#)
- [Viewing Waveform Results](#)

Summary Report

In the summary report (`summary.rpt`), there are two tables of information for each net. The first table provides, in its header, the name of the net, the simulation temperature, and the measurement window or the start and stop time for the analyses. For each net, the table lists the layer name and the corresponding maximum value of each analysis type for that layer. Information for different types of analyses is displayed in different columns.

The second table lists the layer names. For each layer and analysis type, there are two columns of information. The first column lists the number of resistors on which the analysis was run (`analysistype_run_on`) and the second column lists the number of resistors that were ignored in the analysis (`analysistype_num_skip`). The two columns are repeated for different types of analyses.

Net name	AVIDD				
Sim temperature	100				
Measurement window	0 - 3e-08				
Layer	vmax	iacpeak	irms	iavg	imax
cont_ndiff	0,00588592	0	0	0	0
cont_pdiff	0,00716551	0	0	0	0
metal1_conn	0,00709353	0,227128	0,202578	0,615683	0,382038
metal2_conn	0,00685771	0,37514	0,369304	1,40086	0,46849
metal3_conn	0,00612212	0,411409	0,363731	1,17214	0,647951
mwires	0,00716551	0	0	0	0
via1	0,00689822	0	0	0,732529	0
via2	0,00619215	0	0	0,726726	0

Layer	vmax_run_on	vmax_num_skip	vmax_num_unmatch	iacpeak_run_on	iacpeak_num_skip	iacpeak_num_unmatch
cont_ndiff	49	0	0	0	49	0
cont_pdiff	309	0	0	0	309	0
metal1_conn	622	0	0	622	0	622
metal2_conn	71	0	0	71	0	71
metal3_conn	2	0	0	2	0	2

Related Topics

- [IR Report](#)
- [EM Report](#)

Voltus-XFi Custom Power Integrity Solution User Guide

Viewing EM-IR Analysis Results

- [Unmatched Resistor Report](#)
- [Pin Current Report](#)

Unmatched Resistor Report

The unmatched resistor report (*.rpt_unmatch) displays any resistors that may not have a corresponding EM rule received from the foundry.

```
ELECTROMIGRATION ANALYSIS RESULTS

VERSION = v06.88-s080_1
BINARY FILE = 
mp_DiffOpAmp_TRAN_top_1
TECH FILE = /g
EM Only ICT File = /i
RESULTS FILE CREATED = 
USER SUPPLIED VALUES:
RESULTS TYPE = tran
TRANSIENT START = 0 s
TRANSIENT STOP = 3e-08 s
SIM TEMPERATURE = 100 C
SIM HIERARCHY = i0
DSPF SUBCKT NAME = DiffOpAmp
DSPF GLOBAL TEMPERATURE = 25 C
DSPF OPERATING TEMPERATURE = 25 C
Tj = 100 C
deltaT = 5
AVERAGE = t
AVERAGE ABS = t
AVERAGE POS = nil
ACPEAK = t
CUSTOM = nil
RMS = t
PEAK = t
# EM limit calculation for parasitic resistor with length=0 and width=1e5 is skipped
# as this is pseudo resistor from EM analysis viewpoint

----- NET "AVSS" -----
----- NET "outp" -----
----- NET "Ibias" -----
----- NET "inm" -----
----- NET "AVDD" -----
```

Related Topics

- [Summary Report](#)
- [IR Report](#)
- [EM Report](#)
- [Pin Current Report](#)

Pin Current Report

The pin current report (*.rpt_pin) displays the current flow into each pin of the device.

PIN CURRENT RESULTS

```
VERSION           = v06.18-s434_1
BINARY FILE       = /servers/scratch05/pallabi/testcases/VoltusFi_Testcases/EMIR_RAK_DSPF
RESULTS FILE CREATED = 2020-Dec-05 19:23:28 (2020-Dec-05 13:53:28 GMT)
USER SUPPLIED VALUES:
  RESULTS TYPE     = tran
  TRANSIENT START  = 0
  TRANSIENT STOP   = 1e-07
```

----- NET "AVSS" -----

Name	Imax (A)	Iavg (A)	Irms (A)
AVSS	-3.21692m	-3.01910m	3.02014m

----- NET "outp" -----

Name	Imax (A)	Iavg (A)	Irms (A)
outp	-1.38923m	-35.4533u	548.546u

----- NET "Ibias" -----

Name	Imax (A)	Iavg (A)	Irms (A)
Ibias	-50.0011u	-50.0000u	50.0000u

Related Topics

- [Summary Report](#)
- [EM Report](#)
- [Unmatched Resistor Report](#)
- [Pin Current Report](#)

Viewing Waveform Results

To view the current and voltage waveforms in VIVA Waveform Viewer:

1. On the Voltus-XFi window, choose *Results* from the task pane.
2. Select an analysis, test, and corner for which you want to view the reports.
3. Select the *Plots* tab.
4. In the *Layout View* section, select the layout, cell, and view from the respective drop-down lists.
5. Click the *Open* button.
The Virtuoso Visualization & Analysis window opens in a new tab.

Related Topics

- [Visualizing EM-IR Analysis Results using Voltus-XFi Results Browser](#)
- [Viewing EM-IR Analysis Reports](#)

Environment Variables

This section contains the Voltus-XFi environment variable names, descriptions, types, and values. You can customize the operation and behavior of the Voltus-XFi product by changing the value of a particular environment variable.

You can specify environment settings and initialization instructions for Voltus-XFi in the `.cdsenv` and `.cdsinit` files, respectively. Using these settings, you can customize your software environment.

ambientTemp

Specifies the ambient temperature, in degree Celsius, for EM analysis. If this value is not specified, the tool calculates it as $T_j - \Delta T$.

To set this variable in the `.cdsinit` file or CIW, use the call:

```
envSetVal("voltusXFi.em" "ambientTemp" 'string "temperature")
```

To set this variable in the `.cdsenv` file, use the call:

```
voltusXFi.em ambientTemp string "temperature"
```

Variable Type	string
Default Value	Tsim
Acceptable Values	Any string value
GUI Equivalent	<i>Ambient Temperature</i>

blockingDeviceFile

Specifies a file containing the list of cells to ignore during extraction.

To set this variable in the `.cdsinit` file or CIW, use the call:

Voltus-XFi Custom Power Integrity Solution User Guide

Environment Variables

```
envSetVal("voltusXFi.em" "blockingDeviceFile" 'string "file")
```

To set this variable in the `.cdsenv` file, use the call:

```
voltusXFi.em blockingDeviceFile string "file"
```

Variable Type	string
Default Value	nil
Acceptable Values	Any string value
GUI Equivalent	<i>Blocking Device Cells File</i>

compressDSPF

Generates the DSPF file in a compressed format.

To set this variable in the `.cdsinit` file or CIW, use the call:

```
envSetVal("voltusXFi.ext" "compressDSPF" 'boolean nil)
```

To set this variable in the `.cdsenv` file, use the call:

```
voltusXFi.ext compressDSPF boolean nil
```

Variable Type	boolean
Default Value	t
Acceptable Values	t,nil
GUI Equivalent	<i>Compress output DSPF File</i>

cornerName

Specifies the name of the corner at which extraction will be performed.

To set this variable in the `.cdsinit` file or CIW, use the call:

```
envSetVal("voltusXFi.ext" "cornerName" 'string "rcx_typical")
```

To set this variable in the `.cdsenv` file, use the call:

```
voltusXFi.ext cornerName string "rcx_typical"
```

Voltus-XFi Custom Power Integrity Solution User Guide

Environment Variables

Variable Type	string
Default Value	nil
Acceptable Values	Any string value
GUI Equivalent	<i>Corner</i>

customFoundrySetupDir

Specifies the directory path to the custom foundry setup details.

To set this variable in the `.cdsinit` file or CIW, use the call:

```
envSetVal("voltusXFi.project" "customFoundrySetupDir" 'string "directory_path")
```

To set this variable in the `.cdsenv` file, use the call:

```
voltusXFi.project customFoundrySetupDir string "directory_path"
```

Variable Type	string
Default Value	nil
Acceptable Values	Any string value
GUI Equivalent	

dataSource

Specifies the source of EM data.

To set this variable in the `.cdsinit` file or CIW, use the call:

```
envSetVal("voltusXFi.em" "dataSource" 'cyclic "source")
```

To set this variable in the `.cdsenv` file, use the call:

```
voltusXFi.em dataSource cyclic "source"
```

Variable Type	cyclic
Default Value	ICT-EM

Voltus-XFi Custom Power Integrity Solution User Guide

Environment Variables

Acceptable Values ICT File / Quantus Techfile, ICT-EM, EM-Data File, and iRCX-EM

GUI Equivalent *EM Data Source*

deltaTemp

Specifies the maximum rise in temperature, in degree Celsius, caused due to Joule heating. It must be a positive value.

To set this variable in the `.cdsinit` file or CIW, use the call:

```
envSetVal("voltusXFi.em" "deltaTemp" 'int "temperature")
```

To set this variable in the `.cdsenv` file, use the call:

```
voltusXFi.em deltaTemp int "temperature"
```

Variable Type	int
Default Value	5
Acceptable Values	Positive value
GUI Equivalent	<i>Delta T</i>

designResistorFile

Specifies an existing design resistor setup file.

To set this variable in the `.cdsinit` file or CIW, use the call:

```
envSetVal("voltusXFi.em" "designResistorFile" 'string "file")
```

To set this variable in the `.cdsenv` file, use the call:

```
voltusXFi.em designResistorFile string "file"
```

Variable Type	string
Default Value	nil
Acceptable Values	Any string value
GUI Equivalent	<i>Design Resistors</i>

designResistorUnit

Defines the unit for the width and length property names of design resistor cells.

To set this variable in the `.cdsinit` file or CIW, use the call:

```
envSetVal("voltusXFi.em" "designResistorUnit" 'string "unit")
```

To set this variable in the `.cdsenv` file, use the call:

```
voltusXFi.em designResistorUnit string "unit"
```

Variable Type	string
Default Value	nil
Acceptable Values	Any string value
GUI Equivalent	

dfIILayerMapFile

Specifies the DFII layer map file that provides the mapping between the layer names in the extractor-generated xDSPF file to the DFII layer names.

To set this variable in the `.cdsinit` file or CIW, use the call:

```
envSetVal("voltusXFi.browser" "dfIILayerMapFile" 'string  
"EMIR_workshop/df2layermap")
```

To set this variable in the `.cdsenv` file, use the call:

```
voltusXFi.browser dfIILayerMapFile string "EMIR_workshop/df2layermap"
```

Variable Type	string
Default Value	nil
Acceptable Values	Any string value
GUI Equivalent	

dspfNetListExtraPort

Allows you to set the *DSPF Extra Ports* option for EMIR analysis. This option allows you to specify how to handle extra ports in the DSPF or schematic subcircuit definition. By default, this variable is set to `t`, which implies that the extra ports in the DSPF subcircuit call are changed to internal nodes. When you set this option to `nil`, it implies that the port number in the schematic and the DSPF file needs to be the same. If not, the simulation will stop.

To set this variable in the `.cdsinit` file or CIW, use the call:

```
envSetVal("voltusXFi.sim" "dspfNetListExtraPort" 'boolean nil)
```

To set this variable in the `.cdsenv` file, use the call:

```
voltusXFi.sim dspfNetListExtraPort boolean nil
```

Variable Type `boolean`

Default Value `t`

Acceptable Values `t,nil`

GUI Equivalent

dynamicAnalysisOptionsFile

Specifies a file containing additional options for the EM-IR run.

To set this variable in the `.cdsinit` file or CIW, use the call:

```
envSetVal("voltusXFi.sim" "dynamicAnalysisOptionsFile" 'string "file")
```

To set this variable in the `.cdsenv` file, use the call:

```
voltusXFi.sim dynamicAnalysisOptionsFile string "file"
```

Variable Type `string`

Default Value `nil`

Acceptable Values Any string value

GUI Equivalent *Miscellaneous - Options File*

emRuleFile

Specifies the file containing the EM reliability rules.

To set this variable in the `.cdsinit` file or CIW, use the call:

```
envSetVal("voltusXFi.em" "emRuleFile" 'string "file")
```

To set this variable in the `.cdsenv` file, use the call:

```
voltusXFi.em emRuleFile string "file"
```

Variable Type	string
Default Value	nil
Acceptable Values	Any string value
GUI Equivalent	<i>EM Rule File</i>

enableBalloon

Displays information balloon for the selected node/resistor on the layout canvas.

To set this variable in the `.cdsinit` file or CIW, use the call:

```
envSetVal("voltusXFi.browser" "enableBalloon" 'boolean t)
```

To set this variable in the `.cdsenv` file, use the call:

```
voltusXFi.browser enableBalloon boolean t
```

Variable Type	boolean
Default Value	t
Acceptable Values	t
GUI Equivalent	

enableFIT

Enables failures-in-time (FIT) analysis.

To set this variable in the `.cdsinit` file or CIW, use the call:

Voltus-XFi Custom Power Integrity Solution User Guide

Environment Variables

```
envSetVal("voltusXFi.em" "enableFIT" 'boolean t)
```

To set this variable in the `.cdsenv` file, use the call:

```
voltusXFi.em enableFIT boolean t
```

Variable Type	boolean
Default Value	nil
Acceptable Values	t, nil
GUI Equivalent	

enableSmallerPrecision

Displays smaller precision IR drop values in the *IR* tab of the Voltus-XFi Results Browser assistant.

To set this variable in the `.cdsinit` file or CIW, use the call:

```
envSetVal("voltusXFi.browser" "enableSmallerPrecision" 'boolean t)
```

To set this variable in the `.cdsenv` file, use the call:

```
voltusXFi.browser enableSmallerPrecision boolean t
```

Variable Type	boolean
Default Value	nil
Acceptable Values	t, nil
GUI Equivalent	

enableViolationColoring

Enables coloring of nodes/resistors with the violation color when plots are shown.

To set this variable in the `.cdsinit` file or CIW, use the call:

```
envSetVal("voltusXFi.browser" "enableViolationColoring" 'boolean t')
```

To set this variable in the `.cdsenv` file, use the call:

```
voltusXFi.browser enableViolationColoring boolean t
```

Voltus-XFi Custom Power Integrity Solution User Guide

Environment Variables

Variable Type	boolean
Default Value	t
Acceptable Values	t
GUI Equivalent	

enableHeatSink

Specifies that the heat-sink effect should be included in SHE analysis.

To set this variable in the `.cdsinit` file or CIW, use the call:

```
envSetVal("voltusXFi.em" "enableHeatSink" 'boolean t)
```

To set this variable in the `.cdsenv` file, use the call:

```
voltusXFi.em enableHeatSink boolean t
```

Variable Type	boolean
Default Value	nil
Acceptable Values	t
GUI Equivalent	<i>Heat Sink</i>

enableSHE

Enables self-heating effect (SHE) analysis.

To set this variable in the `.cdsinit` file or CIW, use the call:

```
envSetVal("voltusXFi.em" "enableSHE" 'boolean t)
```

To set this variable in the `.cdsenv` file, use the call:

```
voltusXFi.em enableSHE boolean t
```

Variable Type	boolean
Default Value	nil

Voltus-XFi Custom Power Integrity Solution User Guide

Environment Variables

Acceptable Values	t
GUI Equivalent	<i>Enable SHE</i>

extractionDir

Specifies the directory in which the extraction results will be saved.

To set this variable in the `.cdsinit` file or CIW, use the call:

```
envSetVal("voltusXFi.project" "extractionDir" 'string "file")
```

To set this variable in the `.cdsenv` file, use the call:

```
voltusXFi.project extractionDir string "file"
```

Variable Type	string
Default Value	nil
Acceptable Values	Any string value
GUI Equivalent	<i>Extraction Output Directory</i>

extractionMode

Specifies the extraction type and the coupling mode.

To set this variable in the `.cdsinit` file or CIW, use the call:

```
envSetVal("voltusXFi.ext" "extractionMode" 'string "RC decoupled")
```

To set this variable in the `.cdsenv` file, use the call:

```
voltusXFi.ext extractionMode string "RC decoupled"
```

Variable Type	string
Default Value	RC decoupled
Acceptable Values	ROnly, RC Decoupled, and RC Coupled
GUI Equivalent	<i>Extraction Mode</i>

foundry

Specifies the foundry.

To set this variable in the `.cdsinit` file or CIW, use the call:

```
envSetVal("voltusXFi.project" "foundry" 'string "foundry_name")
```

To set this variable in the `.cdsenv` file, use the call:

```
voltusXFi.project foundry string "foundry_name"
```

Variable Type	string
Default Value	Generic
Acceptable Values	Generic or <i>foundry name</i>
GUI Equivalent	<i>Foundry</i>

fractureViaCount

Specifies the number that will be used to divide pseudo vias into segments during extraction.

To set this variable in the `.cdsinit` file or CIW, use the call:

```
envSetVal("voltusXFi.ext" "fractureViaCount" 'int "1")
```

To set this variable in the `.cdsenv` file, use the call:

```
voltusXFi.ext fractureViaCount int "1"
```

Variable Type	int
Default Value	1
Acceptable Values	Any integer value
GUI Equivalent	<i>Fracture Via Count</i>

includetCmdFile

Specifies the file with user-customized extract commands.

Voltus-XFi Custom Power Integrity Solution User Guide

Environment Variables

To set this variable in the `.cdsinit` file or CIW, use the call:

```
envSetVal("voltusXFi.ext" "includeCmdFile" 'string "file")
```

To set this variable in the `.cdsenv` file, use the call:

```
voltusXFi.ext includeCmdFile string "file"
```

Variable Type	string
Default Value	nil
Acceptable Values	Any string value
GUI Equivalent	<i>Include Command File</i>

lifeTime

Specifies the lifetime for which the EM analysis will be performed.

To set this variable in the `.cdsinit` file or CIW, use the call:

```
envSetVal("voltusXFi.ext" "lifeTime" 'string "87600h")
```

To set this variable in the `.cdsenv` file, use the call:

```
voltusXFi.ext lifeTime string "87600h"
```

Variable Type	string
Default Value	87600h
Acceptable Values	Any integer value
GUI Equivalent	<i>Via Array Count</i>

loadResultsSettingsFile

Specifies to load the `.json` file containing the result loading settings that was saved using the *DB Load Options* form.

To set this variable in the `.cdsinit` file or CIW, use the call:

```
envSetVal("voltusXFi.browser" "loadResultsSettingsFile" 'string  
"./ResultsSettings.json")
```

Voltus-XFi Custom Power Integrity Solution User Guide

Environment Variables

To set this variable in the `.cdsenv` file, use the call:

```
voltusXFi.browser loadResultsSettingsFile string "./ResultsSettings.json"
```

Variable Type	string
Default Value	nil
Acceptable Values	Any string value
GUI Equivalent	

lvsSource

Lets you specify the source of the Layout Versus Schematic (LVS) input data.

To set this variable in the `.cdsinit` file or CIW, use the call:

```
envSetVal("voltusXFi.ext" "lvsSource" 'string "Calibre")
```

To set this variable in the `.cdsenv` file, use the call:

```
voltusXFi.ext lvsSource string "Calibre"
```

Variable Type	string
Default Value	PVS/Pegasus
Acceptable Values	"Calibre", "PVS/Pegasus"
GUI Equivalent	<i>LVS Source</i>

modeFit

Specifies the mode of FIT analysis.

To set this variable in the `.cdsinit` file or CIW, use the call:

```
envSetVal("voltusXFi.em" "modeFit" 'string "sdc_at_env_T")
```

To set this variable in the `.cdsenv` file, use the call:

```
voltusXFi.em modeFit string "sdc_at_env_T"
```

Voltus-XFi Custom Power Integrity Solution User Guide

Environment Variables

Variable Type	string
Default Value	sdc_at_env_T
Acceptable Values	Any string value (sdc_at_env_T or sdc_at_seb_T)
GUI Equivalent	<i>Mode</i>

modeSHE

Specifies the mode of SHE analysis.

To set this variable in the `.cdsinit` file or CIW, use the call:

```
envSetVal("voltusXFi.em" "modeSHE" 'string "Region")
```

To set this variable in the `.cdsenv` file, use the call:

```
voltusXFi.em modeSHE string "Region"
```

Variable Type	string
Default Value	Region
Acceptable Values	Any string value (Region or Tiles)
GUI Equivalent	<i>Mode</i>

node

Specifies the process node.

To set this variable in the `.cdsinit` file or CIW, use the call:

```
envSetVal("voltusXFi.project" "node" 'string "node")
```

To set this variable in the `.cdsenv` file, use the call:

```
voltusXFi.project node string "node"
```

Variable Type	string
----------------------	--------

Voltus-XFi Custom Power Integrity Solution User Guide

Environment Variables

Default Value	gpdk045
Acceptable Values	gpdk045, n3, n4, n5, n7prf, n7, n10, n12, n14, n16, n20, n22, n28
GUI Equivalent	<i>Node</i>

paramFileFit

Specifies the SHE analysis parameter (param.sh) file with the FIT information for all segments of metals and vias.

To set this variable in the `.cdsinit` file or CIW, use the call:

```
envSetVal("voltusXFi.em" "paramFileFit" 'string "file")
```

To set this variable in the `.cdsenv` file, use the call:

```
voltusXFi.em paramFileFit string "file"
```

Variable Type	string
Default Value	nil
Acceptable Values	Any string value
GUI Equivalent	<i>Parameter File</i>

paramFileSHE

Specifies the SHE analysis parameter (param.sh) file, which is required for calculating the SHE analysis results with heat-sink effect.

To set this variable in the `.cdsinit` file or CIW, use the call:

```
envSetVal("voltusXFi.em" "paramFileSHE" 'string "file")
```

To set this variable in the `.cdsenv` file, use the call:

```
voltusXFi.em paramFileSHE string "file"
```

Variable Type	string
Default Value	nil

Voltus-XFi Custom Power Integrity Solution User Guide

Environment Variables

Acceptable Values	Any string value
GUI Equivalent	<i>Parameter File</i>

pinOrderFile

Specifies the sub-circuit pin order file to provide the order of pins to be used during extraction.

To set this variable in the `.cdsinit` file or CIW, use the call:

```
envSetVal("voltusXFi.em" "pinOrderFile" 'string  
"/VoltusXFi_workshop/pin2pin.conf")
```

To set this variable in the `.cdsenv` file, use the call:

```
voltusXFi.em pinOrderFile string "/VoltusXFi_workshop/pin2pin.conf"
```

Variable Type	string
Default Value	nil
Acceptable Values	Any string value
GUI Equivalent	<i>Pin Order File</i>

productLife

Specifies the lifetime of product in hours.

To set this variable in the `.cdsinit` file or CIW, use the call:

```
envSetVal("voltusXFi.em" "productLife" 'int "1")
```

To set this variable in the `.cdsenv` file, use the call:

```
voltusXFi.em productLife int "1"
```

Variable Type	int
Default Value	1
Acceptable Values	Any integer value
GUI Equivalent	<i>Product Life</i>

projectDir

Specifies the directory in which the EM-IR analysis results will be saved.

To set this variable in the `.cdsinit` file or CIW, use the call:

```
envSetVal("voltusXFi.project" "projectDir" 'string "directory")
```

To set this variable in the `.cdsenv` file, use the call:

```
voltusXFi.project outputDir string "directory"
```

Variable Type	string
Default Value	nil
Acceptable Values	Any string value
GUI Equivalent	<i>Project Directory</i>

qrcTechFile

Specifies the name of the Quantus technology file.

To set this variable in the `.cdsinit` file or CIW, use the call:

```
envSetVal("voltusXFi.em" "qrcTechFile" 'string "file")
```

To set this variable in the `.cdsenv` file, use the call:

```
voltusXFi.em qrcTechFile string "file"
```

Variable Type	string
Default Value	nil
Acceptable Values	Any string value
GUI Equivalent	<i>TechFile</i>

RCType

Specifies the extraction type and the coupling mode.

To set this variable in the `.cdsinit` file or CIW, use the call:

Voltus-XFi Custom Power Integrity Solution User Guide

Environment Variables

```
envSetVal("voltusXFi.ext" "RCType" 'string "RC decoupled")
```

To set this variable in the `.cdsenv` file, use the call:

```
voltusXFi.ext RCType string "RC decoupled"
```

Variable Type	string
Default Value	RC decoupled
Acceptable Values	ROnly, RC Decoupled, and RC Coupled
GUI Equivalent	<i>Extraction Mode</i>

rciRCXFile

Specifies the RC iRCX file provided by the foundry to be used for EM analysis.

To set this variable in the `.cdsinit` file or CIW, use the call:

```
envSetVal("voltusXFi.em" "rciRCXFile" 'string "file")
```

To set this variable in the `.cdsenv` file, use the call:

```
voltusXFi.em rciRCXFile string "file"
```

Variable Type	string
Default Value	nil
Acceptable Values	Any string value
GUI Equivalent	

signalNetsIRFile

Specifies a file from which the table data is automatically populated to the *IR* tab in the *Signal Nets* tab for the Dynamic Analysis Setup type.

To set this variable in the `.cdsinit` file or CIW, use the call:

```
envSetVal("voltusXFi.sim" "signalNetsIRFile" 'string "file")
```

To set this variable in the `.cdsenv` file, use the call:

```
voltusXFi.sim signalNetsIRFile string "file"
```

Voltus-XFi Custom Power Integrity Solution User Guide

Environment Variables

Variable Type	string
Default Value	nil
Acceptable Values	Any string value
GUI Equivalent	<i>Load Signal Nets IR Setup</i>

simulationDir

Specifies the directory in which the simulation results will be saved.

To set this variable in the `.cdsinit` file or CIW, use the call:

```
envSetVal("voltusXFi.project" "simulationDir" 'string "file")
```

To set this variable in the `.cdsenv` file, use the call:

```
voltusXFi.project simulationDir string "file"
```

Variable Type	string
Default Value	nil
Acceptable Values	Any string value
GUI Equivalent	<i>Simulation Output Directory</i>

techDir

Specifies the directory that contains the technology file.

To set this variable in the `.cdsinit` file or CIW, use the call:

```
envSetVal("voltusXFi.ext" "techDir" 'string "directory")
```

To set this variable in the `.cdsenv` file, use the call:

```
voltusXFi.ext techDir string "directory"
```

Variable Type	string
Default Value	nil

Voltus-XFi Custom Power Integrity Solution User Guide

Environment Variables

Acceptable Values	Any string value
GUI Equivalent	<i>Technology Directory</i>

techLibraryFile

Specifies the file to be used for reading the technology data.

To set this variable in the `.cdsinit` file or CIW, use the call:

```
envSetVal("voltusXFi.ext" "techLibraryFile" 'string "file")
```

To set this variable in the `.cdsenv` file, use the call:

```
voltusXFi.ext techLibraryFile string "file"
```

Variable Type	string
Default Value	nil
Acceptable Values	Any string value
GUI Equivalent	<i>Technology Library File</i>

techName

Specifies the technology filename to be used for extraction.

To set this variable in the `.cdsinit` file or CIW, use the call:

```
envSetVal("voltusXFi.ext" "techName" 'string "name")
```

To set this variable in the `.cdsenv` file, use the call:

```
voltusXFi.ext techName string "name"
```

Variable Type	string
Default Value	nil
Acceptable Values	Any string value
GUI Equivalent	<i>Technology Name</i>

Voltus-XFi Custom Power Integrity Solution User Guide

Environment Variables

temp

Specifies the temperature, in degree Celsius, at which the EM analysis will be run.

To set this variable in the `.cdsinit` file or CIW, use the call:

```
envSetVal("voltusXFi.em" "temp" 'string "Tsim")
```

To set this variable in the `.cdsenv` file, use the call:

```
voltusXFi.em temp string "Tsim"
```

Variable Type	string
Default Value	Tsim
Acceptable Values	Any string value
GUI Equivalent	<i>EM Temperature</i>

tileXSHE

Specifies the number of tiles in the X direction for the Tiles mode of SHE analysis.

To set this variable in the `.cdsinit` file or CIW, use the call:

```
envSetVal("voltusXFi.em" "tileXSHE" 'int "value")
```

To set this variable in the `.cdsenv` file, use the call:

```
voltusXFi.em tileXSHE int "value"
```

Variable Type	int
Default Value	1
Acceptable Values	Any integer value
GUI Equivalent	<i>X</i>

tileYSHE

Specifies the number of tiles in the Y direction for the Tiles mode of SHE analysis.

To set this variable in the `.cdsinit` file or CIW, use the call:

Voltus-XFi Custom Power Integrity Solution User Guide

Environment Variables

```
envSetVal("voltusXFi.em" "tileYSHE" 'int "value")
```

To set this variable in the `.cdsenv` file, use the call:

```
voltusXFi.em tileYSHE int "value"
```

Variable Type	int
Default Value	1
Acceptable Values	Any integer value
GUI Equivalent	Y

useSeparateDirs

Specifies to save the results for extraction and simulation data in separate directories.

To set this variable in the `.cdsinit` file or CIW, use the call:

```
envSetVal("voltusXFi.project" "useSeparateDirs" 'boolean nil)
```

To set this variable in the `.cdsenv` file, use the call:

```
voltusXFi.project useSeparateDirs boolean nil
```

Variable Type	boolean
Default Value	t
Acceptable Values	t,nil
GUI Equivalent	<i>Use separate directories for extraction, simulation</i>

useTempCoeff

Specifies that the `temp_coeff` value specified in the CCL file will be used for extraction.

To set this variable in the `.cdsinit` file or CIW, use the call:

```
envSetVal("voltusXFi.ext" "useTempCoeff" 'boolean nil)
```

To set this variable in the `.cdsenv` file, use the call:

```
voltusXFi.ext useTempCoeff boolean nil
```

Variable Type	boolean
Default Value	t
Acceptable Values	t,nil
GUI Equivalent	<i>Use temperature coefficient for extracted resistors</i>

viaArrayCount

Specifies the number of vias per side allowed in an array (without the per via layer count option).

To set this variable in the `.cdsinit` file or CIW, use the call:

```
envSetVal("voltusXFi.ext" "viaArrayCount" 'int "2")
```

To set this variable in the `.cdsenv` file, use the call:

```
voltusXFi.ext viaArrayCount int "2"
```

Variable Type	int
Default Value	4
Acceptable Values	Any integer value
GUI Equivalent	<i>Via Array Count</i>

viaArraySpacing

Sets the via spacing automatically. This variable specifies the distance that will be used as the maximum distance criteria for grouping vias within the same array. This means that if the distance between vias is less than the specified maximum distance, they are grouped within the same array.

To set this variable in the `.cdsinit` file or CIW, use the call:

```
envSetVal("voltusXFi.ext" "viaArraySpacing" 'string "auto")
```

To set this variable in the `.cdsenv` file, use the call:

```
voltusXFi.ext viaArraySpacing string "auto"
```

Voltus-XFi Custom Power Integrity Solution User Guide

Environment Variables

Variable Type	string
Default Value	auto
Acceptable Values	Any integer value
GUI Equivalent	<i>Via Array Spacing (auto)</i>

uriModelFile

Specifies a file containing all ECO changes for a specific what-if run. This variable is supported only for solver method 2-Stage.

To set this variable in the `.cdsinit` file or CIW, use the call:

```
envSetVal("voltusXFi.ext" "uriModelFile" 'string "file")
```

To set this variable in the `.cdsenv` file, use the call:

```
voltusXFi.ext uriModelFile string "file"
```

Variable Type	string
Default Value	nil
Acceptable Values	Any string value
GUI Equivalent	<i>Miscellaneous - ECO File</i>

Related Topics

- [Specifying Custom Foundry and Node Information](#)

Voltus-XFi EM-IR Form Description

This section contains the field descriptions of the Voltus-XFi EM-IR GUI:

- [Voltus-XFi EM-IR GUI – Setup Tab](#)
- [Voltus-XFi EM-IR GUI – Run Tab](#)
- [Voltus-XFi EM-IR GUI – Results Tab](#)
- [Voltus-XFi EM-IR GUI – Diagnostic Tools Tab](#)

Related Topics

- [Specifying EM Rule Settings](#)
- [Specifying Power Nets for EM-IR Analysis](#)
- [Specifying Parasitic Extraction Settings](#)
- [Specifying Simulation Settings](#)
- [Running Post Layout Simulation](#)

Voltus-XFi EM-IR GUI – Setup Tab

Lets you specify the netlist extraction and EM and IR analysis settings.

Setup – Project Tab

Field	Description
<i>Process Info</i>	
<i>Foundry</i>	Lets you select the foundry for which you want to run EM-IR analysis.

Voltus-XFi Custom Power Integrity Solution User Guide

Voltus-XFi EM-IR Form Description

Field	Description
<i>Node</i>	Lets you select the process node associated with the foundry.
Layout View	Specifies the library, cell, and view to be opened in ADE.
Results Directory	
<i>Output Directory</i>	Specifies the directory in which the EM-IR analysis results will be saved.
<i>Use separate directories for extraction, simulation</i>	Lets you specify if you want to save the results for extraction and simulation in separate directories.
<i>Extraction Output Directory</i>	Specifies the directory in which the extraction results will be saved.
<i>Simulation Output Directory</i>	Specifies the directory in which the simulation results will be saved.

Setup – Electromigration Tab

Field	Description
EM Settings	
<i>EM Data Source</i>	<p>Specifies the format of EM rules. The following options are available:</p> <ul style="list-style-type: none"> ■ <i>ICT File</i>: Interconnect technology (ICT) file ■ <i>ICT-EM</i>: ICT file containing only EM rules ■ <i>EM Data File</i>: File that specifies the technology information, such as current density limits, and provides a mapping between the layers for highlighting. ■ <i>iRCX-EM</i>: Interoperable interconnect extraction (iRCX) file contains the process and EM model information for EM analysis and is provided by the foundry.
<i>TechFile</i>	Specifies the Quantus technology file.
<i>EM Rule File</i>	Specifies the file containing the EM reliability rules.
<i>EM Temperature</i>	Specifies the temperature, in degree Celsius, at which the EM analysis will be run. The default <i>EM Temperature</i> is set to <i>Tsim</i> (simulation temperature).

Voltus-XFi Custom Power Integrity Solution User Guide

Voltus-XFi EM-IR Form Description

Field	Description
<i>Ambient Temperature</i>	Specifies the ambient temperature, in degree Celsius, for EM analysis. The default <i>Ambient Temperature</i> is set to <i>Tsim</i> (simulation temperature).
<i>Delta T</i>	Specifies the maximum rise in temperature, in degree Celsius, caused due to Joule heating. It must be a positive value.
<i>Lifetime</i>	Specifies the lifetime for which the EM analysis will be run. You can specify the value in hours or years.
<i>Design Resistors</i>	Specifies the list of design resistors. For each resistor, you can specify the resistor model name, width, length, and layer name. You can either load an existing design resistor setup, or add design resistor models and save the setup.
Thermal Analysis Settings	
<i>Layout Cellview</i>	Specifies the Virtuoso Layout view.
SHE	
<i>Enable SHE</i>	Enables self-heating effect (SHE) analysis.
<i>Heat Sink</i>	Specifies that the heat-sink effect should be included in SHE analysis.
<i>Mode</i>	<p>Specifies the mode of SHE analysis. The following options are available:</p> <ul style="list-style-type: none"> ■ <i>Region</i>: Specifies that thermal reports will contain temperature rise of OD region and metal resistors. ■ <i>Tiles</i>: Specifies that thermal reports will contain temperature rise of OD region and metal resistors based on the specified tile matrix. <p>When you select <i>Tiles</i>, two additional fields, <i>X</i> and <i>Y</i> appear in which you need to specify the x and y coordinates of the tiles.</p>
<i>Parameter File</i>	<p>Specifies the SHE analysis parameter (<code>param.sh</code>) file, which is required for calculating the SHE analysis results with heat-sink effect.</p> <p>Note: The information contained in the <code>param.sh</code> file is proprietary. To use this file, you need a collateral from the foundry.</p>

Voltus-XFi Custom Power Integrity Solution User Guide

Voltus-XFi EM-IR Form Description

Field	Description
<i>FIT</i>	
<i>Enable FIT</i>	Enables failures-in-time (FIT) analysis.
<i>Product Life</i>	Specifies the lifetime of product in hours.
<i>Mode</i>	Specifies the mode of FIT analysis. The following options are available: <ul style="list-style-type: none"> ■ <i>sdc_at_env_T</i>: Calculates SDC at the environment temperature. ■ <i>sdc_at_seb_T</i>: Calculates SDC at the statistical EM budgeting (SEB) temperature.
<i>Parameter File</i>	Specifies the SHE analysis parameter (<code>param.sh</code>) file with the FIT information for all segments of metals and vias.

Setup – Power Nets Tab

Field	Description
<i>Power Nets</i>	
<i>Select from schematic</i>	Lets you select power nets in the schematic.
<i>Net Name</i>	Specifies the name of a power net.
<i>Net Type</i>	Lets you specify a net as a global power or ground net, group and ungroup nets, move nets to a group, and remove a net.

Setup – Extraction Tab

Field	Description
<i>Add Setup</i>	Lets you specify the various extraction settings.
<i>Name</i>	Specifies the name of the extraction run for which you are defining the settings.

Voltus-XFi Custom Power Integrity Solution User Guide

Voltus-XFi EM-IR Form Description

Field	Description
<i>Existing DSPF</i>	<p>Specifies that an existing Detailed Standard Parasitic Format (DSPF) file will be used for EM-IR analysis. Click the <i>Browse (...)</i> button to select a DSPF file.</p> <p>The DSPF file is a third-party netlist file that is used to provide all the parasitic information of the design for performing simulations using the Spectre X simulator.</p>
<i>Existing CCL</i>	<p>Specifies that an existing common command language (CCL) file will be used for EM-IR analysis.</p> <p>Click the <i>Browse (...)</i> button next to the <i>CCL File</i> field to select a file. The CCL file contains the commands and options that define the extraction run.</p> <p>Click the <i>Browse (...)</i> button next to the <i>DSPF File</i> field to specify the location of the generated DSPF file.</p>
<i>Custom</i>	Allows to generate a new extraction setup.
<i>Run DSPF Linter</i>	Specifies to run the spfchecker utility on DSPF. The DSPF Linter utility analyzes a DSPF file, reports problems that may cause simulation problems, and creates an EM-IR conf file with recommended mapping statements.
<i>Job Policy</i>	Allows you to set up an extraction job policy and define the methods of how distributed processing jobs are submitted to the local or remote hosts.
Technology	
<i>File/Directory</i>	<p>Lets you specify one of the following:</p> <ul style="list-style-type: none"> ■ <i>Technology Library File</i>: Specifies the file to be used for reading the technology data. ■ <i>Technology Directory</i>: Specifies the directory that contains the technology file.
<i>Technology Name</i>	<p>Specifies the name of the technology to be used for extraction.</p> <p>This field appears only when you select a technology library file for reading the technology data.</p>

Voltus-XFi Custom Power Integrity Solution User Guide

Voltus-XFi EM-IR Form Description

Field	Description
<i>Corners</i>	<p>Lets you specify the corners and the temperature of the corners at which the extraction will be performed.</p> <p>This field appears only when you select a technology library file for reading the technology data.</p>
<i>Use temperature coefficient for extracted resistors</i>	<p>Specifies that the <code>temp_coeff</code> value specified in the CCL file will be used for extraction.</p> <p>If you select this check box, you cannot specify the temperature of the individual corners. The options, <i>Temp</i> and <code>temp_coeff</code> specified in the CCL file, are mutually exclusive.</p>
<i>Temp</i>	<p>Specifies the temperature at which the extraction will be performed. By default, a temperature of 25 degree Celsius is used.</p> <p>The options, <i>Temp</i> and <i>Use temperature coefficient for extracted resistors</i>, are mutually exclusive.</p>
Input	
<i>LVS Source</i>	<p>Lets you specify whether the Layout Versus Schematic (LVS) input data will come from. The following options are available:</p> <ul style="list-style-type: none"> ■ <i>Calibre</i> ■ <i>PVS/Pegasus</i> (default value)
<i>LVS Query Output Directory</i>	<p>Specifies the path to the directory in which the input LVS data is stored.</p>
<i>Run Name</i>	<p>Specifies the name of the LVS run.</p>
Type	

Voltus-XFi Custom Power Integrity Solution User Guide
 Voltus-XFi EM-IR Form Description

Field	Description
<i>Type</i>	<p>Specifies the extraction type and the coupling mode. The following extraction options are available:</p> <ul style="list-style-type: none"> ■ <i>RC</i>: Specifies that both parasitic resistors and capacitors will be extracted. ■ <i>R only</i>: Specifies that only parasitic resistors will be extracted. <p>When <i>R only</i> is selected, the simulation time is short. While selecting the extraction mode, consider the type of simulation being run. For example, to run a DC operating point (DCOP) simulation, select <i>R only</i> as the extraction mode because the capacitance values are not required.</p> <p>The following coupling modes are available:</p> <ul style="list-style-type: none"> ■ <i>coupled</i>: Specifies that coupled capacitance extraction will be performed. ■ <i>decoupled</i>: Specifies that decoupled capacitance extraction will be performed.
<i>Output</i>	
<i>Format</i>	Specifies the format of extraction output file.
<i>Advanced Settings for Input/Parasitics/Output</i>	
<i>Input</i>	

Voltus-XFi Custom Power Integrity Solution User Guide

Voltus-XFi EM-IR Form Description

Field	Description
<i>Pin Order File</i>	<p>Specifies the file that contains the order of pins to be used during extraction.</p> <p>The pin order is specified in the DSPF file using the <code>.SUBCKT</code> and <code>.ENDS</code> statements. You can use this option to provide a file with a different pin order that will override the order specified using the default <code>.SUBCKT</code> statement in the DSPF file.</p> <p>Below are examples of pin orders in the DSPF file before and after specifying the pin order file.</p> <p>Without the pin order file:</p> <pre>.SUBCKT top In_001 VDD Out_001 VSS In_002 Out_002 In_003 Out_004ENDS</pre> <p>With the pin order file:</p> <pre>.SUBCKT top VDD VSS In_001 Out_001 In_002 Out_002 In_003 Out_004ENDS</pre>
<i>Blocking Device Cells File</i>	Specifies the file containing the parasitic blocking device cell names, if any. Parasitic extraction for these devices are skipped.
<i>Include Command File</i>	Lets you specify the file with user-customized extract commands.
Parasitics	
<i>Via Array Spacing</i>	<p>Specifies the distance that will be used as the maximum distance criteria for grouping vias within the same array. This means that if the distance between vias is less than the specified maximum distance, they are grouped within the same array.</p> <p>The default value of the via array spacing is 0.35 times the via size for N10, N16, N12, and N20 processes. For other processes, the default is <i>auto</i>, in which case Voltus-XFi sets the via spacing automatically.</p>
<i>Via Array Count</i>	<p>Specifies the number of vias per side allowed in an array (without the per via layer count option).</p> <p>The default value is 4. For example, if the via array count is set to 2, the number of vias allowed per array side will be 2.</p>

Voltus-XFi Custom Power Integrity Solution User Guide
 Voltus-XFi EM-IR Form Description

Field	Description
<i>Fracture Via Count</i>	Specifies the number that will be used to divide the pseudo vias into segments during extraction
Output	
Resistor Settings	
<i>Add parasitic resistor color (mask number)</i>	Enables color-aware EM analysis.
<i>Add subconductor layer name</i>	Includes information about the parasitic resistor models for the subconductor layers. This is used to support different EM rules for poly layers during EM analysis.
Filter	
<i>Suppress instance cards (*II) for C only nets</i>	Specifies that the instance cards and the corresponding dummy resistors for the capacitance-only nets are not printed in the results.
<i>Center resistors</i>	Includes sub-nodes after eliminating resistors with small resistance values. When this option is selected, the survivor sub-nodes, among a group of sub-nodes that are formed by the filtered resistors, are chosen based on their proximity to the geometric center of the group. This field is specific to process nodes 5nm and below.
<i>Specify minimum resistance per layer</i>	Lets you specify the LVS layer name for which the minimum resistance value for the extracted parasitic resistors is to be applied. If the layer name is not specified, the default value, RH_TN_6 0, is used. This field is specific to process nodes 5nm and below.
Misc	
<i>Ground Net Node</i>	Lets you select the reference or ground net node.
<i>Subnode Character</i>	Specifies the subnode identification character. By default, : is specified.
<i>Comment top subckt</i>	Comments out the top sub circuit statements from the DSPF file.
<i>Compress output DSPF File</i>	Generates the DSPF file in a compressed format.

Voltus-XFi Custom Power Integrity Solution User Guide
 Voltus-XFi EM-IR Form Description



Setup – Analyses Tab

Field	Description
<i>Add Dynamic Analysis/ Add SPGS Analysis/ Add Static Analysis</i>	Lets you specify the various EM analysis settings.
<i>Dynamic Analysis Setup/ SPGS Analysis Setup/ Static Analysis Setup</i>	
<i>Name</i>	Specifies the name of the analysis run for which you are defining the settings.
<i>Testbench Tab</i>	
<i>Testbench Information</i>	Allows you to select a library, cell, and maestro view to be opened in ADE.
<i>Open</i>	Opens the maestro view in ADE.
<i>Active Setup</i>	Indicates to select the active or current simulation setup in ADE.
<i>Setup State</i>	Indicates to select a previously saved simulation setup in ADE.
<i>Window Tab</i>	
<i>Time Window</i>	<p>Specifies the duration of EM-IR analysis. The following options are available:</p> <ul style="list-style-type: none"> ■ <i>Full Transient Time</i>: Specifies that the EM-IR analysis is run over the entire simulation period. ■ <i>Custom</i>: You can select the time window of EM-IR analysis and provide the start and stop times.
<i>Power Nets Tab</i>	
<i>IR Analysis</i>	
<i>Compute maximum IR drop (vmax)</i>	Calculates the maximum IR drop value of each power net.
<i>Compute average IR drop (vavg)</i>	Calculates the average IR drop value of each power net.
<i>EM Analysis</i>	
<i>Compute peak EM violation (ipeak)</i>	Calculates the peak current violation value of each power net.

Voltus-XFi Custom Power Integrity Solution User Guide
 Voltus-XFi EM-IR Form Description

Field	Description
<i>Compute average EM violation (iavg)</i>	Calculates the average current violation value of each power net.
<i>Compute RMS EM violation (irms)</i>	Calculates the root mean square (RMS) current violation value of each power net.
Specify Power Nets	
<i>Enable</i>	Allows to select the power net to be included for EM-IR analysis.
<i>Net name</i>	Specifies the power net name.
<i>Voltage Regulator Nets</i>	<p>Allows to select the voltage regulator nets to be included for EM-IR analysis. Click <i>Select nets from schematic</i> to select the nets in the schematic.</p> <p>In this tab, you can specify the following:</p> <ul style="list-style-type: none"> ■ <i>Analysis</i> - Compute node maximum or average IR drop compared to reference. ■ <i>Reference Voltage</i> - Use either maximum voltage of all nodes at each timepoint, average voltage of all nodes at each timepoint, net pin node as reference, or specified voltage value as reference to calculate IR drop. ■ <i>Ref-Node</i> - Use specified node of net as reference. ■ <i>Vref</i> - Use the specified voltage reference value.
Signal Nets Tab	
EM Analysis	
<i>Compute peak EM violation (ipeak)</i>	Calculates the peak current violation value of each signal net.
<i>Compute average EM violation (iavg)</i>	Calculates the average current violation value of each signal net.
<i>Compute RMS EM violation (irms)</i>	Calculates the root mean square (RMS) current violation value of each signal net.
EM	
<i>Enable</i>	Allows to select the signal net to be included for EM analysis.
<i>Net name</i>	Specifies the signal net name.

Voltus-XFi Custom Power Integrity Solution User Guide
 Voltus-XFi EM-IR Form Description

Field	Description
IR	
	Lets you load the table data from a file.
	Lets you save the table data to a file.
<i>Enable</i>	Allows to select the signal net on which IR drop analysis is to be performed.
<i>Net name</i>	Specifies the signal net name that is not connected to any voltage source.
<i>Analysis</i>	Specifies to compute node maximum (sigvmax), average (sigvavg), or absolute average (sigvabsavg) IR drop compared to reference.
<i>Ref Voltage</i>	Specifies to use either maximum voltage of all nodes at each timepoint, average voltage of all nodes at each timepoint, net pin node as reference, or specified voltage value as reference to calculate IR drop.
<i>Ref-Node</i>	Allows to use the specified node of net as reference.
<i>Vref(V)</i>	Allows to use the specified voltage reference value.
<i>Select from Schematic</i>	Lets you select signal nets in the schematic.
Solver Tab	
Solver Settings	

Voltus-XFi Custom Power Integrity Solution User Guide

Voltus-XFi EM-IR Form Description

Field	Description
<i>Method</i>	<p>Specifies the solver method with which the EM-IR analysis will be run. The following options are available:</p> <ul style="list-style-type: none"> ■ <i>Direct</i>: When high accuracy is needed, a brute-force simulation of the entire system – circuit plus parasitic resistances and capacitances – can be performed to accurately calculate EM-IR of any net. This approach is called the “one-step” method, where the EM-IR simulation performance and capacity is subject to the limitation of the circuit simulator being used. ■ <i>2-stage</i>: To conduct EM-IR simulation on circuits with much larger power and signal nets, within a shorter time, there is an alternative approach that involves decoupling the nonlinear circuit simulation from the linear RC net analysis. You can iterate the linear RC net analysis by modifying the layout; however, the nonlinear circuit simulation is done only once. This approach is called the “two-step” method. The decoupling of the linear RC nets from the nonlinear circuit is not mathematically equivalent to the original design and certain inaccuracy is introduced but it provides the benefit of simulation performance and capacity.
<i>EMIR Preset</i>	<p>Specifies the options that let you trade off accuracy and performance. These options not only control solver settings, but also enable parasitic optimization after automatically detecting post-layout designs.</p> <p>The possible values for this option are <i>cx</i>, <i>ax</i>, <i>mx</i>, <i>lx</i>, and <i>vx</i>, with <i>cx</i> being the most accurate mode and <i>vx</i> the highest performing mode.</p> <ul style="list-style-type: none"> ■ Use <i>cx</i> when a golden reference is required. ■ Use <i>ax</i> for high-precision analog applications. ■ Use <i>mx</i> for most analog applications. This is the default mode. ■ Use <i>lx</i> for power management and other relaxed analog application circuits. ■ Use <i>vx</i> for custom IC verification.

Voltus-XFi Custom Power Integrity Solution User Guide
 Voltus-XFi EM-IR Form Description

Field	Description
Advanced Tab	
Advanced Analysis Settings	
<i>Toggle Frequency</i>	Specifies the frequency of the nets so that the tool can derive the Td (total on-time period) for multiple clock cycles. You can specify frequencies for different nets as shown below: (NETA, 4.6e9) (NETB, 2.3e9)
<i>Toggle Net Frequency File</i>	Specifies the name of the file that contains the net names and their corresponding frequency values. This file is used to specify the frequency of nets to compute the Td (total on-time period) for multiple clock cycles. This file contains net names separated by commas and the frequency values. A sample frequency file is shown below: NETA, 4.6e9 NETB, 2.3e9
Peak	
<i>AC Peak Analysis (iacpeak)</i>	Specifies to calculate the current density violations based on the peak AC current for metal lines, vias, and contacts. It is applied to periodic AC or pulsed DC signals.
<i>Dynamic AC Peak</i>	When you set dynamic AC peak to single or multiple peak, it is important to set the Pulse Width Threshold. Td has different values for the single or multiple peak values of dynamic AC peak: <ul style="list-style-type: none"> ■ Single Peak - When dynamic AC peak is single, Td=the time duration of maximum peak. ■ Multiple Peak - When dynamic AC peak is multiple peak, Td=sum of time durations of different peaks, Td1+Td2+TdN....
<i>Pulse Width Threshold</i>	Enables pulse-wise EM current calculation for violation visualization. This option defines the current threshold for finding the start of the pulse. Any value below the threshold value is considered as zero.
<i>Multiple Peak Threshold</i>	Specifies the threshold percentage for the peak current above which the Td for a particular peak is added to the final Td. It is used to calculate the pulse width for a given peak.

Voltus-XFi Custom Power Integrity Solution User Guide
 Voltus-XFi EM-IR Form Description

Field	Description
Average	
<i>Use Recovery Factor</i>	<p>Specifies whether or not layer-wise recovery factor is to be used for calculating the average current density.</p> <p>If the recovery factor is specified, then the average current density calculation is as follows:</p> $i_{avg} = \max(i_{avgpos} , i_{avgneg}) - \text{recovery_factor} * \min(i_{avgpos} , i_{avgneg})$ <p>If not specified, then $i_{avg} = i_{avgpos} + i_{avgneg}$</p> <p>where i_{avgpos} is the average current in the positive direction and i_{avgneg} is the average current in the negative direction.</p>
<i>Recovery Factor</i>	<p>Calculates the effective DC electromigration in the bipolar current waveforms. This accounts for some 'sweep back recovery' of EM during the negative portion of the current waveform.</p> <p>The following equation shows how the recovery factor is used by the software while calculating the total average EM current:</p> $I (avg) = \max(I+, I-) - (\text{recovery factor}) * \min(I+, I-)$ <p>where $I+$ is the average of I in the positive direction and $I-$ is the average of I in the negative direction</p>
<i>Average Absolute Current (iavgabs)</i>	Specifies to calculate the current density violations based on the average value of absolute current.
Miscellaneous	
<i>Options File</i>	Specifies a file containing additional options for the EMIR run.
<i>ECO File</i>	Enables what-if analysis and applies the changes defined in the ECO file.
ECO	
<i>Net Name</i>	Specifies the name of the net for which conversion between pins, tap nodes, and subnodes are to be done.

Voltus-XFi Custom Power Integrity Solution User Guide
 Voltus-XFi EM-IR Form Description

Field	Description
<i>Conversion Type</i>	Species the type of conversion. The possible options are: <ul style="list-style-type: none"> ■ Pins to Subnodes ■ Pins to Taps ■ Subnodes to Taps ■ Subnodes to Pins ■ Taps to Pins ■ Taps to Subnodes
<i>Include</i>	Specifies the tap/pin/node to be included.
<i>Exclude</i>	Specifies the tap/pin/node to be excluded.
<i>DSPF Layer</i>	Specifies the name of the DSPF layer on which conversion is performed.

Voltus-XFi EM-IR GUI – Run Tab

Lets you start an extraction or analysis run.

Field	Description
<i>Job Status</i>	
<i>Run Name</i>	Specifies the name of the extraction or analysis run.
<i>Analysis</i>	Specifies the type of run: extraction or analysis.
<i>Stop/Rerun</i>	Provides the options to stop a run and restart a run. After the extraction run is complete, you must stop this run before starting the analysis run.
<i>Progress</i>	Displays the progress of the current run.
<i>Status</i>	Displays the status of the current run.

Voltus-XFi EM-IR GUI – Results Tab

Lets you view and analyze the EM and IR analysis results.

Field	Description
<i>Project Directory</i>	Specifies the path to the Voltus-XFi simulation results directory.
Plots	
Layout View	
<i>Layout</i>	Select the name of the library, cell and view in which you want to load the results.
<i>Load Results</i>	Loads the EM-IR analysis results on the layout.
Waveform Results	
<i>Results Database</i>	Opens the selected corner waveform data in ViVa.

Voltus-XFi EM-IR GUI – Diagnostic Tools Tab

Lets you run DSPF Linter on a DSPF netlist file.

Field	Description
<i>Enable</i>	Specifies to run DSPF Linter on the selected DSPF netlist file.
<i>DSPF File</i>	Specifies the DSPF file to be used for running the DSPF Linter utility.
<i>Size</i>	Specifies the size of the DSPF file.
<i>Options</i>	Specifies additional options for running DSPF Linter.
<i>Run/Stop</i>	Specifies to start or stop the DSPF Linter utility.

Voltus-XFi Custom Power Integrity Solution User Guide
Voltus-XFi EM-IR Form Description

SKILL Functions

This section provides syntax, description, and examples for the Cadence® SKILL functions associated with the Voltus-XFi Custom Power Integrity Solution flow.

Only the functions documented in this chapter are supported for public use. Any other functions, and undocumented aspects of the functions described below, are private and subject to change or removal at any time.

vxfiLoadNets

```
vxfiLoadNets(  
    w_windowId  
    netname  
)  
=> t / nil
```

Description

Specifies to load the nets in the Voltus-XFi Result Browser. This function should be called after the `vxfiOpenLayout` and `vxfiLoadEMIRResults` functions.

Arguments

<i>w_windowId</i>	Specifies the window ID returned by the <code>vxfiOpenLayout</code> function.
<i>netname</i>	Specifies the net to be loaded. You can specify multiple net names separated by a space.

Value Returned

t	The nets were loaded successfully.
nil	The nets were not loaded.

Examples

```
winId = vxfiOpenLayout("Two_Stage_Opamp" "DiffOpAmp" "layout")  
vxfiLoadEMIRResults( winId "top.emirtap.emir0.wdb") vxfiLoadNets(winId  
list("avdd", "avss"))
```

The above example code shows that the name of the nets for loading is `avdd` and `avss`.

vxfiLoadEMIRResults

```
vxfiLoadEMIRResults(  
    w_windowId  
    resultsdatabase  
)  
=> t / nil
```

Description

Specifies to load the EMIR results database file (.wdb) in the Voltus-XFi Result Browser. This function should be called after the `vxfiOpenLayout` function.

Arguments

<code>w_windowId</code>	Specifies the window ID returned by the <code>vxfiOpenLayout</code> function.
<code>resultsdatabase</code>	Specifies the name of the EMIR results database file (.wdb) to be used for loading and displaying the EMIR analysis results in the Voltus-XFi Results Browser.

Value Returned

<code>t</code>	The results were loaded successfully.
<code>nil</code>	The results were not loaded.

Examples

```
winId = vxfiOpenLayout("Two_Stage_Opamp" "DiffOpAmp" "layout")  
vxfiLoadEMIRResults( winId "top.emirtap.emir0.wdb")
```

The above example code shows that the name of the results file specified for loading and displaying EMIR analysis results in Voltus-XFi is `top.emirtap.emir0.wdb`.

vxfiOpenLayout

```
vxfiOpenLayout (  
    libname  
    cellname  
    viewname  
    [ mode ]  
)  
=> w_windowId
```

Description

Opens the design in the Virtuoso layout and launches Voltus-XFi Results Browser.

Arguments

<i>libname</i>	Specifies the library name for the design to be opened.
<i>cellname</i>	Specifies the cell name for the design to be opened.
<i>viewname</i>	Specifies the layout view name for the design to be opened.
<i>mode</i>	Specifies whether the layout is in the read or edit mode. Possible values are "read" and "edit". The default mode is edit.

Value Returned

w_windowId The ID of the window.

Examples

```
winId = vxfiOpenLayout("Two_Stage_Opamp" "OpAmp_AC_top" "maestro_basic" "read")
```

The above example opens the design in read mode.

```
winId = vxfiOpenLayout("Two_Stage_Opamp" "OpAmp_AC_top" "maestro_basic" "edit")
```

The above example opens the design in edit mode.

vxfiSaveNetSummaryInfoToCSV

```
vxfiSaveNetSummaryInfoToCSV(  
    filename  
    w_windowId  
)
```

Description

Specifies to write the net summary given in the Voltus-XFi Results Browser interface to a text file in the current working directory.

Arguments

<i>filename</i>	Specifies the name of the text file containing a summary of all the nets in the design for which the EMIR analysis is done.
<i>w_windowId</i>	Specifies the window ID of the Voltus-XFi window or the layout window from where the net summary is output.

Value Returned

None

Examples

```
vxfiSaveNetSummaryInfoToCSV("net_summary_file.txt")
```

The above example code shows that the name of the text file specified for displaying net summary in Voltus-XFi is net_summary_file.txt.

vxfiSessionConnect

```
vxfiSessionConnect (  
    t_sessionName  
    t_signalName  
    s_callbackFunction  
)  
=> t / nil
```

Description

Registers a SKILL callback to be connected to a known signal or trigger emitted from a Voltus-XFi session. This function supports event-based trigger callbacks for pre-extraction, post-extraction, and pre-simulation. The function can be used to run LVS before running extraction, after running extraction, and before running simulation by registering the LVS run callback for these three events.

Arguments

t_sessionName Specifies the name of the Voltus-XFi session name.

t_signalName Name of the signal or trigger emitted by the Voltus-XFi session for which to register a callback.

s_callbackFunction Symbol representing the callback function to be called when the signal is emitted.

Value Returned

t Successful operation

nil Unsuccessful operation

Examples

The following example shows how to connect a custom function, `_preExtractionRunCallback`, with the `preExtractionRun` trigger.

```
(defun _preExtractionRunCallback (vxfiSession extName)  
vxfiSetLVSQueryOutputDirectory(vxfiSession, extName, "./golden_files/lvs_run/  
svdb/")  
vxfiSetLVSRunName(vxfiSession, extName, "DiffOpAmp")  
)
```

Voltus-XFi Custom Power Integrity Solution User Guide

SKILL Functions

```
(procedure (sessionConnectHandlers session)
  (vxfiSessionConnect session "preExtractionRun" '_preExtractionRunCallback)
  t
)

(vxfiSessionRegisterCreationCallback 'sessionConnectHandlers)
```

vxfiSessionRegisterCreationCallback

```
vxfiSessionRegisterCreationCallback(  
    s_callbackFunction  
)  
=> t / nil
```

Description

Registers a SKILL function as callback to be called whenever the event for which it is registered is occurred.

Arguments

s_callbackFunction SKILL symbol representing the callback function to be called upon creation of a new Voltus-XFi session.

Value Returned

t	Successful operation
nil	Unsuccessful operation

Examples

The following example registers callback from the .cdsinit file:

```
(procedure (sessionConnectHandlers session)  
    (vxfiSessionConnect session "preExtractionRun" '_preExtractionRunCallback)  
    t  
)  
  
(vxfiSessionRegisterCreationCallback 'sessionConnectHandlers)
```

vxfiSetLVSQueryOutputDirectory

```
vxfiSetLVSQueryOutputDirectory(  
    t_sessionName  
    t_runName  
    t_directory  
)
```

Description

Specifies the path to the LVS output directory in which the input data is stored for extraction.

Arguments

t_sessionName Specifies the name of the Voltus-XFi session name.
t_runName Specifies the run name used while running extraction.
t_directory Specifies the LVS run directory name.

Value Returned

None

Examples

The following example specifies that the name of the LVS directory is svdb:

```
vxfiSetLVSQueryOutputDirectory(vxfiSession, extName, "./golden_files/lvs_run/  
svdb/")
```

vxfiSetLVSRunName

```
vxfiSetLVSRunName (  
    t_sessionName  
    t_runName  
    t_lvstrunName  
)
```

Description

Specifies the LVS run name to be used for extraction.

Arguments

t_sessionName Specifies the name of the Voltus-XFi session name.
t_runName Specifies the run name used while running extraction.
t_lvstrunName Specifies the name of the LVS run.

Value Returned

None

Examples

The following example specifies that the name of the LVS run name is DiffOpAmp:

```
vxfiSetLVSRunName(vxfiSession, extName, "DiffOpAmp")
```